



**10EER W090A-W180B Series MEGA-TEC™**

Bard Manufacturing's revolutionary MEGA-TEC® WALL-MOUNT sets the industry standard for flexibility. Engineered to cool virtually any equipment building or shelter, the PLC technology inside the unit and controller provides unmatched cooling and unparalleled control over your critical application. The MEGA-TEC® is AHRI certified, meets or exceeds DOE efficiency requirements, and delivers industrial grade service at the highest possible level of efficiency. The MEGA-TEC® moves seamlessly between three different compressor cooling capacities based on need and peak efficiency, and thanks to our Programmable Logic Control (PLC) technology, you'll be able to control up to fourteen units with a single controller.

- Complies with efficiency requirements of ASHRAE/IESNA 90.1-2019.
- Certified to ASNI/ARI Standard 390-2003 for SPVU (Single Package Vertical Units).
- Intertek ETL Listed to Standard for Safety Heating and Cooling Equipment ANSI/UL 1995/CSA 22.2 No. 236-05 Fourth Edition.
- Commercial Product - Not intended for residential applications.
- Bard is an ISO 9001:2015 Certified Manufacturer.
- The AHRI Certified® mark indicates Bard Manufacturing Company participation in the AHRI Certification program. For verification of individual certified products, go to [www.ahridirectory.org](http://www.ahridirectory.org).



**BARDHVAC.COM**

FORM NO. S3565-0323



**Climate Control Solutions**

	page
<b>Interactive Table of Contents (Select topic with cursor to go to location, pick to return)</b>	<b>2</b>
<b>Wall-Mount Nomenclature</b>	<b>3</b>
<b>Engineered Features - MEGA-TEC Exterior</b>	<b>4</b>
<b>Engineered Features - MEGA-TEC Interior</b>	<b>5</b>
<b>Unit Modes of Operation</b>	<b>6</b>
<b>Capacity and Efficiency Ratings</b>	<b>7</b>
<b>General Unit Specifications</b>	<b>7</b>
<b>Cooling Application Data at Rated Airflow - Full Load Stage 3 - 60Hz Operation</b>	<b>8</b>
<b>Cooling Application Data at High Sensible Airflow - Full Load Stage 3 - 60Hz Operation</b>	<b>9</b>
<b>Cooling Application Data at Rated Airflow - Full Load Stage 3 - 50Hz Operation</b>	<b>10</b>
<b>Cooling Application Data at High Sensible Airflow - Full Load Stage 3 - 50Hz Operation</b>	<b>10</b>
<b>Electrical Specifications: W090, W120, W150, W180 Units Without Electric Reheat</b>	<b>11</b>
<b>Electrical Specifications: W090, W120, W150, W180 Units With Electric Reheat</b>	<b>12</b>
<b>Electric Heat Table - Refer to Electrical Specifications for Availability by Unit Model</b>	<b>13</b>
<b>MEGA-TEC Ventilation Option Selection Chart</b>	<b>13</b>
<b>Indoor Airflow CFM for Standard Operation, W090, W120, W150, W180 Units</b>	<b>14</b>
<b>MEGA-TEC Filter Option Selection Chart</b>	<b>14</b>
<b>Indoor Fan Curves and Default Torque Settings for Fan Operation, W090, W120, and W150</b>	<b>15</b>
<b>Cabinet Options</b>	<b>16</b>
<b>Evaporator and Condenser Coil Coating Options</b>	<b>16</b>
<b>Packaging Options Including Wood Skids, Metal Skids and Platforms, and Crates.</b>	<b>16</b>
<b>Condenser Section Easy Access</b>	<b>17</b>
<b>Condenser Fan Specifications</b>	<b>17</b>
<b>Evaporator Fan Specifications</b>	<b>17</b>
<b>PLC Logic Board Specifications</b>	<b>17</b>
<b>Cabinet Dimensions - W090, W120, W150 Series Units</b>	<b>18</b>
<b>Cabinet Dimensions - W180 Series Units</b>	<b>19</b>
<b>Clearance Dimensions for W090, W120, W150 Units</b>	<b>20</b>
<b>Clearance Dimensions for W180 Units</b>	<b>20</b>
<b>Factory Supplied Unit Components List</b>	<b>21</b>
<b>Factory Supplied Unit Components List</b>	<b>22</b>
<b>Non-Ducted Supply and Return Grilles</b>	<b>23</b>
<b>Non-Ducted Supply Grille Throw Characteristics</b>	<b>23</b>
<b>Controller Overview</b>	<b>24</b>
<b>LC6000 Multi-Unit Multi-Zone Temperature and Humidity Controller</b>	<b>24</b>
<b>LC6000 Controller Optional Accessories</b>	<b>25</b>
<b>LC6000 Daisy Chain Connection to Units</b>	<b>25</b>
<b>LC6000 Wired Inputs for Site Equipment</b>	<b>25</b>
<b>LC6000 Wired Alarm Outputs</b>	<b>26</b>
<b>LC6000 Remote Connectivity Options</b>	<b>26</b>
<b>MEGA-TEC Unit with TEC-EYE Interface</b>	<b>27</b>
<b>TEC-EYE Accessible Software and Unit Information Features</b>	<b>28</b>
<b>TEC-EYE Configuration Menu Features</b>	<b>29</b>
<b>System Configuration Menu</b>	<b>29</b>
<b>Advanced System Configuration Menu</b>	<b>30</b>
<b>I/O Configuration Menu</b>	<b>30</b>
<b>Unit Field Communication Connections in MEGA-TEC Control Panel</b>	<b>30</b>



# Wall-Mount Nomenclature

Digit # 1 2 3 4 5 6 7 8 9 10 11 12 13 14 15

**W 1 2 0 A P B 0 Z E P X X X X**

**UNIT SERIES**  
Wall-Mount

**NOMINAL CAPACITY**

- 090 - 7.5 Ton
- 120 - 10.0 Ton
- 150 - 12.5 Ton
- 180 - 15.0 Ton

**REVISION**

- A - Revision for W090-W150
- B - Revision for W180

**PLACEHOLDER**

- P - PLC Logic Board
- E - PLC Logic Board and Electric Reheat (Requires 18kw Electric Heat Option).

**VOLTAGE**

- B - 208/230V-60Hz-3Ph (W090-W150 units)
- C - 460V-60Hz-3Ph (W090-W150 units)
- E - 240/220V-50Hz-3Ph (W090-W150 units)
- V - 415/380V-50Hz-3Ph (W090-W150 units)

- S - 208/230V-60Hz-3Ph or 240/220-50-3 (W180 units)
- T - 460V-60Hz-3Ph or 415/380-50-3 (W180 units)

- N - 400V-60Hz-3Ph (W120-W180 Units)
- Q - 575V-60Hz-3Ph (All Units)

See below voltage nomenclature chart for further details

**ELECTRIC HEAT**

- 00 - OKw with Lug Connection
  - 0Z - OKw with Circuit Breaker
  - 09 to 36 - Kw Heat with Circuit Breaker
- See Electrical Specs for further details

**ACCESSORIES AND PACKAGING OPTIONS**

- X - Standard Carton Packaging
- 1, 2, 3, 4, 5, 6, 7 - See Chart Below for details.

**COIL & UNIT COATING OPTIONS**

- X - Standard Copper/Aluminum coils.
- 1 - Coated Evaporator coil.
- 2 - Coated Condenser coil.
- 3 - Coated Evaporator and Condenser coils.

**SUPPLY OUTLET**

- X - Standard

**COLOR AND CABINET FINISH**

- X - Standard Beige baked enamel finish
- 1 - White baked enamel finish
- 4 - Buckeye Gray baked enamel finish
- S - Stainless Steel

**FILTER**

- P - 2" MERV8 Disposable Filter
- M - 2" MERV11 Disposable Filter
- N - 2" MERV13 Disposable Filter

**VENT PACKAGE**

- B - Block Off Plate
- E - Full Flow Economizer, Temperature or Enthalpy

MODELS	FIELD SUPPLIED POWER AND VOLTAGE NOMENCLATURE					
	208/230V-60-3 (197V-253V)	460V-60-3 (414V-506V)	400V-60-3 (380V-420V)	575V-60-3 (520V-630V)	240V/220V-50-3 (197V-253V)	415V-50-3 (342V-456V)
W090	B	C		Q	E	V
W120, W150	B	C	N	Q	E	V
W180	S	T	N	Q	S	T

MODELS	PACKAGING AND ACCESSORY NOMENCLATURE									
	CARTON WITH STANDARD WOOD SKID	CARTON WITH WHITE STEEL SKID/PLATFORM	CRATE WITH STANDARD WOOD SKID	CRATE WITH WHITE STEEL SKID/PLATFORM	CARTON WITH GRAY STEEL SKID/PLATFORM	CRATE WITH GRAY STEEL SKID/PLATFORM	CARTON WITH BEIGE STEEL SKID/PLATFORM	CRATE WITH BEIGE STEEL SKID/PLATFORM	CARTON WITH GALVANIZED STEEL SKID/PLATFORM	CRATE WITH GALVANIZED STEEL SKID/PLATFORM
W090, W120, W150	X	1	2	3	4	5	6	7		
W180									X	1



## ////// Engineered Features - MEGA-TEC Exterior

The exterior of the MEGA-TEC® provides installation features including lifting lugs. Cabinet construction uses 16 gauge and 14 gauge components for strength and durability. Service features includes exterior service ports, a filter replacement light, and hinged upper filter access door.

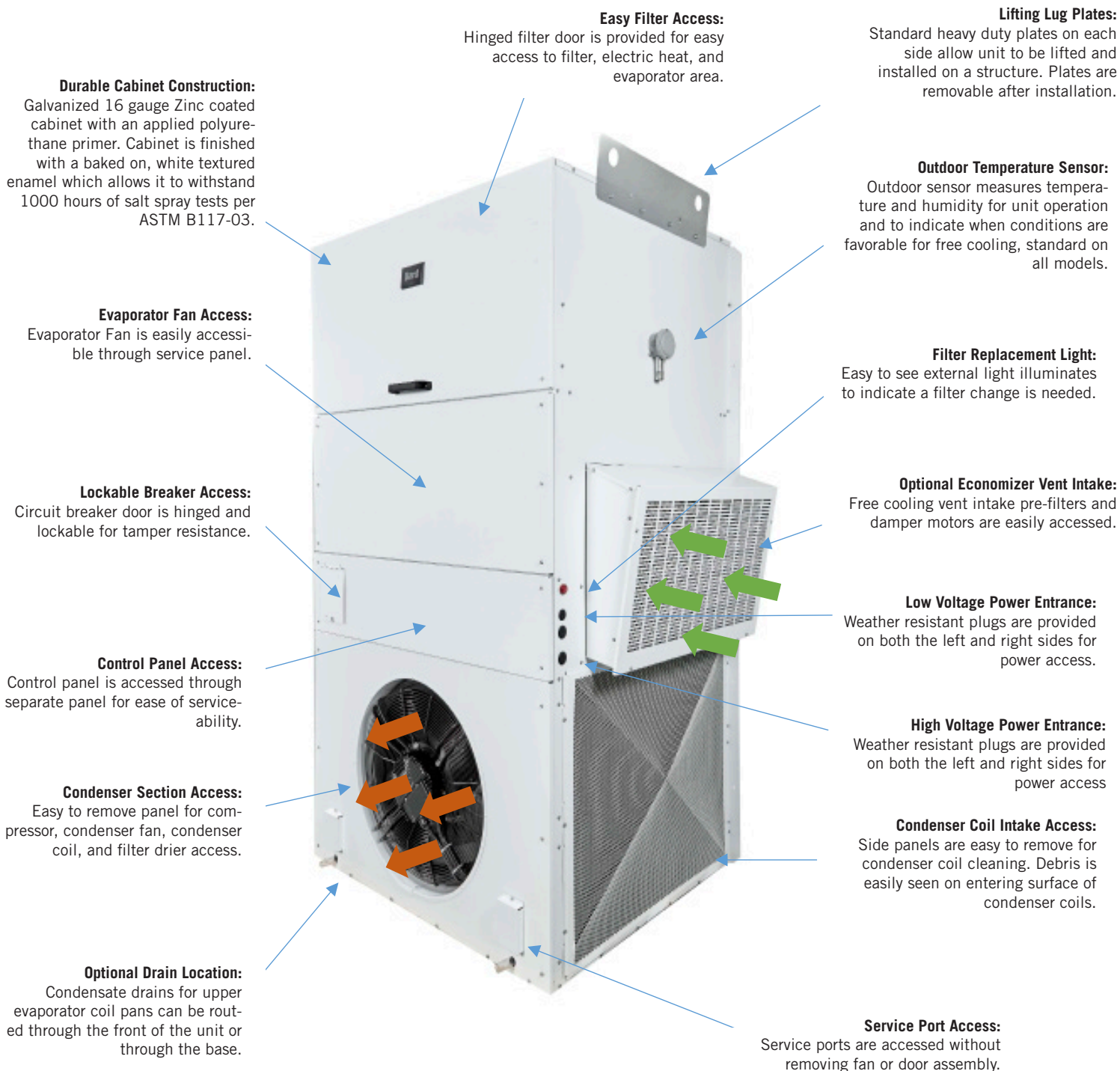

W120 model shown



## ////// Engineered Features - MEGA-TEC Interior

The interior of the MEGA-TEC® provides easily serviceable areas for routine maintenance and is designed for years of trouble free service. A hinged upper filter access door and slide out condenser fan assembly are a few of the features that make the MEGA-TEC® easy to service. Industrial grade fans and components provide dependable service in outdoor work environments. Electronic expansion valves and Modbus controls use the latest technology to provide the best indoor environment for electronics and industrial equipment.

Note: Circuit 1 two-stage on left. Circuit 2 single-stage on right facing front.

### Non-fiberglass Insulation:

Extremely durable closed cell foam insulation used throughout the product.

### Enhanced Latent and High Sensible Cooling Modes:

PLC Logic is used for high sensible cooling where humidity inside the area is at average or low conditions. Balanced Climate operation allows for additional humidity to be removed when moisture levels are high in the area being conditioned.

### Industrial Grade Evaporator Fan:

Evaporator Fan uses ECM technology for efficient, dependable service. Modbus communication used for motor feedback.

### (2) Refrigeration Circuits:

Separate refrigeration circuits use individual compressors for serviceability and reliability

### Industrial Grade Controls:

Control panel is clean, organized, and easy to service.

### Optional Free Cooling:

Economizer option allows for free cooling utilizing outdoor air when conditions are acceptable.

### Liquid Line Filter/Drier:

Filter driers protect refrigeration equipment and are standard in all models.

### Industrial Grade Outdoor Fan:

Outdoor fan uses ECM technology for efficient, dependable service. Modbus communication used for motor feedback.

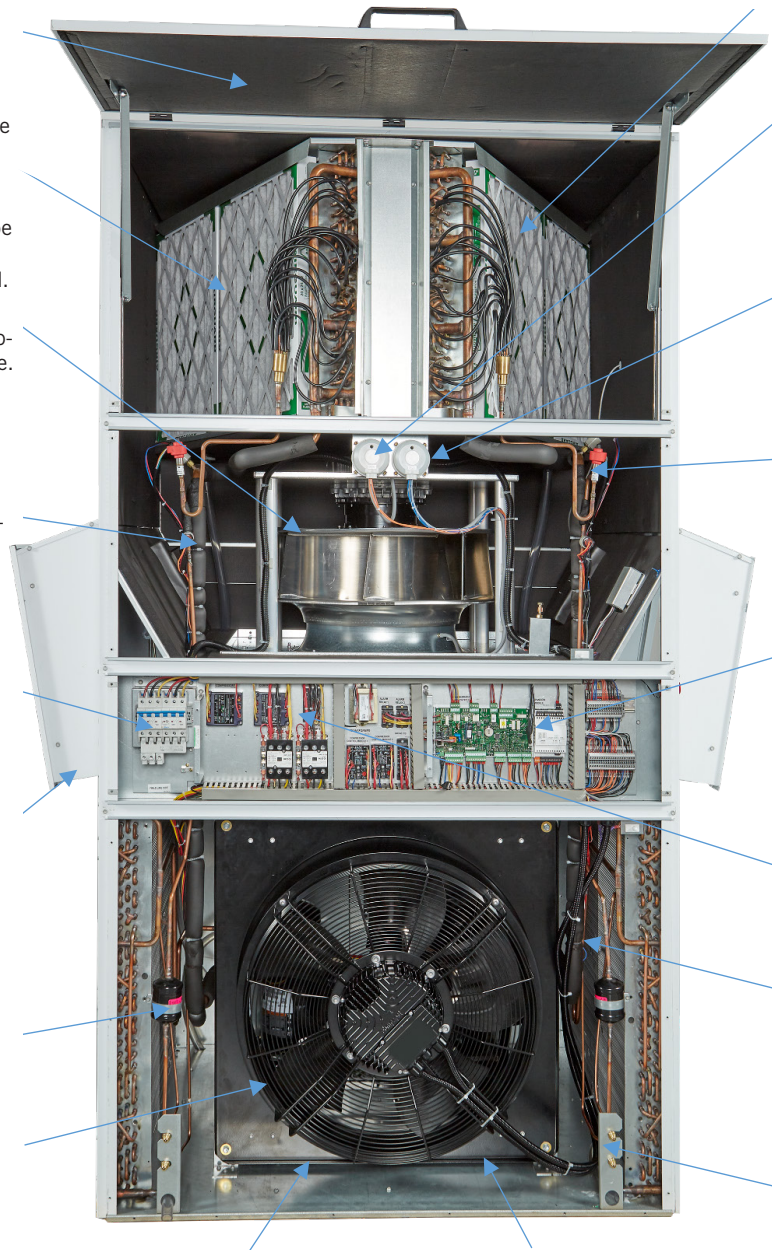

### 2" Pleated Filter:

Large filter area and 2" pleated design allow for better unit indoor airflow.

### Dirty Filter Indicator:

Filter pressure switch with filter change indicator light standard on all models.

### Fan Pressure Switch:

Fan pressure switch to indicate blower failure standard on all models

### Electronic Expansion Valves:

Electronic expansion valves are used in all models for precise superheat control.

### PLC Technology:

Control board uses Modbus to communicate with components and controller.

### Phase Rotation Monitor:

Protects against compressor reverse rotation. Standard on all 3 phase models.

### Pressure Transducers:

High and low side system pressures are monitored to provide refrigeration data including superheat.

### Service Port Access:

Service ports are accessed without removing fan or door assembly.

### Slide-out Fan Assembly:

Slide out condenser fan assembly allows fan to be pulled forward. Hinges allow fan to be rotated out of the way for compressor access.

### Scroll Compressors:

Each refrigeration circuit uses a separate scroll compressor. Three cooling stages provide efficient capacity control for applications with lower heat loads.

W120 model shown

**Cooling Operation:** The Bard MEGA-TEC® Series products offer three stage cooling operation using R410A refrigerant. Cooling is achieved by two independent cooling circuits containing independent scroll compressors (one single stage, one two stage), filter driers, electronic expansion valves (EEV's), condenser coils and evaporator coils. The unit PLC monitors indoor humidity levels, and uses high sensible cooling operation to increase unit airflow when moisture levels do not require an average or substantial amount of latent capacity.

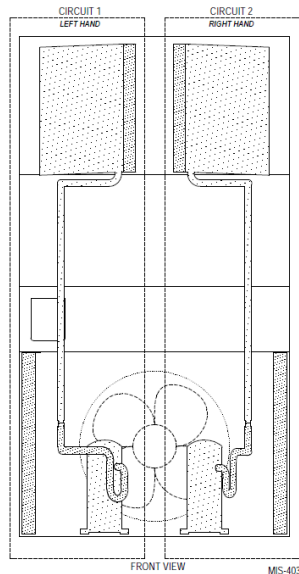

**Heating Operation:** The Bard MEGA-TEC® Series products offer optional two stage heating operation using resistance heaters. Circuit breaker disconnect protection is standard in all 208V to 230V units equipped with electric heat.



**Electric Reheat Dehumidification Operation:** The Bard MEGA-TEC® Series products offer optional electric reheat dehumidification operation that removes moisture from air leaving the unit. The electric heat reheats the cooled supply air after it passes over the evaporator coils. This results in extended compressor runtime and lowering of high indoor humidity levels.



**Economizer Free Cooling Operation:** The Bard MEGA-TEC® Series products offer optional economizer ventilation operation that can achieve extremely high cooling efficiencies by taking advantage of cooler outdoor conditions. Outdoor air is brought into the structure when conditions are acceptable for free cooling through hoods located on both sides of the unit. A large room exhaust path allows room air to be vented outdoors when fresh air is being brought into the structure. Minimum ventilation amounts are user selectable for continuous outdoor intake. Economizer operation allows for free cooling at outdoor temperatures down to -40°F. Emergency cooling and ventilation are safety features that are available with the optional economizer.

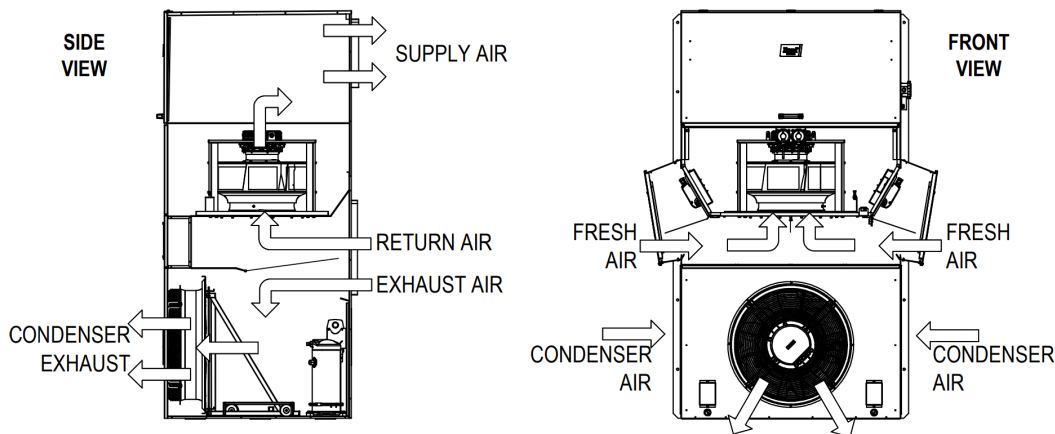

**Balanced Climate™ Operation:** Balanced Climate™ is a great moisture removal feature that operates during cooling operation when moisture levels inside the room are high. By reducing unit airflow and running in compressor cooling operation, latent capacity is increased and additional moisture is removed from the air being conditioned. Balanced Climate™ is a standard feature for all MEGA-TEC® products.



# Capacity and Efficiency Ratings

MODELS	W090	W120	W150	W180
3rd Stage Cooling Capacity in BTUH	90,000 BTUH	123,000 BTUH	146,000 BTUH	178,000 BTUH
3rd Stage Unit efficiency in EER	10.2 EER	10.0 EER	10.0 EER	10.0 EER
2nd Stage Cooling Capacity in BTUH	80,000 BTUH	114,000 BTUH	122,000 BTUH	150,000 BTUH
1st Stage Cooling Capacity in BTUH	30,000 BTUH	42,000 BTUH	44,000 BTUH	58,000 BTUH
IPLV (Integrated Part Load Value)	11.7	12.3	10.6	12.6

Note 1: 60Hz models are certified in accordance with ANSI/ARI Standard 390-2003 and meet or exceed 10 EER DOE requirements. 50Hz models are for export only.

Note 2: EER = Energy Efficiency Ratio and is certified in accordance with ANSI/ARI Standard 390-2003. All ratings based on fresh air intake being 100% closed (no outside air introduction).

Note 3: IPLV = Integrated Part Load Value (IPLV) is a BTU/WATT efficiency measurement that combines staged cooling.

# General Unit Specifications

MODEL	Number of Indoor Fans	Indoor CFM and Rated Static	Indoor Fan HP	Indoor Fan Type	Indoor - Outdoor Fan Communication	Maximum Indoor Fan RPM	Basic Unit Weight	Economizer Option Weight	Standard Packaging Weight	Crate Packaging Weight	Total Unit Charge R410A
W090	1	2850 CFM @ .25 ESP	2	Backward Incline	Modbus	1500 RPM	1190lbs. 539.77kg	100lbs. 45.36kg	100lbs. 45.36kg	300lbs. 136.08kg	16.875lbs. 7.65kg
W120	1	4650 CFM @ .35 ESP	2	Backward Incline	Modbus	1500 RPM	1190lbs. 539.77kg	100lbs. 45.36kg	100lbs. 45.36kg	300lbs. 136.08kg	16.875lbs. 7.65kg
W150	1	4650 CFM @ .35 ESP	2	Backward Incline	Modbus	1500 RPM	1220lbs. 553.38kg	100lbs. 45.36kg	100lbs. 45.36kg	300lbs. 136.08kg	20.500lbs. 9.30kg
W180	2	5400 CFM @ .35 ESP	1.2	Backward Incline	Modbus	1500 RPM	1955lbs. 886.78kg	140lbs. 63.50kg	145lbs. 65.77kg	380lbs. 172.37kg	22.000lbs. 9.98kg

MODEL	Number of compressors and circuits	Compressor Type	Expansion Devices	Pressure Transducer Types	R410A Refrigerant Circuit A	R410A Refrigerant Circuit B	Number of Filters	Filter Size	Number of Outdoor Fans	Outdoor Fan HP	Outdoor Fan Type	Outdoor fan total CFM
W090	2	Scroll	EEV	10k J Curve	8.44lbs 3.83kg	8.44lbs 3.83kg	4	20" x 24" x 2" 51x61x5cm	1	3	Axial Fan, ECM	6200cfm
W120	2	Scroll	EEV	10k J Curve	8.44lbs 3.83kg	8.44lbs 3.83kg	4	20" x 24" x 2" 51x61x5cm	1	3	Axial Fan, ECM	7700cfm
W150	2	Scroll	EEV	10k J Curve	10.25lbs 4.65kg	10.25lbs 4.65kg	4	20" x 24" x 2" 51x61x5cm	1	3	Axial Fan, ECM	7400cfm
W180	2	Scroll	EEV	10k J Curve	11.0lbs 4.99kg	11.0lbs 4.99kg	6	16" x 25" x 2" 41x64x5cm	2	3.2	Axial Fan, ECM	7700cfm

MODEL	Nom.	Nominal Voltage	Hz	Operating Voltage Range	Short Circuit Current (SCCR)	Power Disconnect Type	Branch Circuit Selection Current (BSCS)	Compressor 1 Rated Load Amps (LRA)	Compressor 2 Rated Load Amps	Compressor 1 Locked Rotor Amps (LRA)	Compressor 2 Locked Rotor Amps	Indoor Fan Amps	Outdoor Fan Amps
W090	B	208/230V	60	197-253V	5KA SYM.	C Breaker	27.9A	10.0A/11.0A	10.0A/11.0A	83.1A	83.1A	3.6A	7.2A
	C	460V	60	414-506V	5KA SYM.	T Disconnect	17.3A	7.5A	7.3A	41A	41A	1.9A	2.5A
	Q	575V	60	520-630V	5KA SYM.	T Disconnect	9.5A	4.6A	4.8A	33.0A	33.0A	1.9A	2.5A
	E	240/220V	50	197-253V	5KA SYM.	C Breaker	27.5A	9.8A/10.9A	10.0A/11.0A	80.7A	80.7A	3.6A	7.2A
	V	415/380V	50	342V-456V	5KA SYM.	T Disconnect	14.7A	6.1A	6.1A	43A	43A	1.9A	2.5A
W120	B	208/230V	60	197-253V	5KA SYM.	C Breaker	36.9A	15.0A/16.3A	14.5A/16.0A	136A	136A	3.6A	5.5A
	C	460V	60	414-506V	5KA SYM.	T Disconnect	17.3A	7.9A	7.3A	66.1A	66.1A	1.7A	2.7A
	N	400V	60	380-420V	5KA SYM.	T Disconnect	20.6A	10.3A	10.3A	83A	83A	1.7A	2.7A
	Q	575V	60	520-630V	5KA SYM.	T Disconnect	13.2A	6.1A	6.2A	55.3A	55.3A	1.7A	2.7A
	E	240/220V	50	197-253V	5KA SYM.	C Breaker	36.6A	15.0A/16.1A	14.2A/15.7A	146A	146A	3.6A	5.5A
V	415/380V	50	342V-456V	5KA SYM.	T Disconnect	13.2A	6.1A	6.2A	55.3A	55.3A	1.7A	2.7A	
W150	B	208/230V	60	197-253V	5KA SYM.	C Breaker	36.9A	17.4A/19.2A	19.9A/19.3A	167A	149A	5.5A	7.2A
	C	460V	60	414-506V	5KA SYM.	T Disconnect	17.3A	9.4A	9.1A	69A	75A	2.7A	3.5A
	N	400V	60	380-420V	5KA SYM.	T Disconnect	17.3A	9.4A	9.1A	69A	75A	2.7A	3.5A
	Q	575V	60	520-630V	5KA SYM.	T Disconnect	15.4A	7.6A	7.7A	55A	54A	2.7A	3.5A
	E	240/220V	50	197-253V	5KA SYM.	C Breaker	42.9A	17.4A/19.2A	17.9A/19.3A	167A	149A	5.5A	7.2A
V	415/380V	50	342V-456V	5KA SYM.	T Disconnect	20.6A	9.9A	10.6A	69A	74A	2.7A	3.5A	
W180	S	208/230V	60	197-253V	5KA SYM.	C Breaker	51.9A	22.1A/23.3A	21.1A/22.4A	164A	164A	2.5A x 2	7.5A x 2
		240/220V	50	197-253V	5KA SYM.	C Breaker	51.9A	22.1A/23.3A	22.1A/23.3A	179A	179A	2.5A x 2	7.5A x 2
	T	460V	60	414-506V	5KA SYM.	T Disconnect	24.3A	10.5A	11.0A	94A	100A	1.2A x 2	3.6A x 2
		415/380V	50	342V-456V	5KA SYM.	T Disconnect	24.3A	10.5A	11.0A	94A	92A	1.2A x 2	3.6A x 2
	N	400V	60	380-420V	5KA SYM.	T Disconnect	28.4A	12.3A	12.8A	94A	94.3A	1.4A x 2	4.2A x 2
Q	575V	60	520-630V	5KA SYM.	T Disconnect	18.0A	7.8A	8.1A	65A	78A	1.2A x 2	3.6A x 2	



////// Cooling Application Data at Rated Airflow - Full Load Stage 3 - 60Hz Operation

MODEL	RETURN AIR (DB/WB)	COOLING CAPACITY	Outdoor Temperature											
			75°F 23.9°C	80°F 26.6°C	85°F 29.4°C	90°F 32.2°C	95°F 35°C	100°F 37.7°C	105°F 40.5°C	110°F 43.3°C	115°F 46.1°C	120°F 48.8°C	125°F 51.6°C	131°F 55°C
W090A	75/62°F 23.8/16.6°C	Total	90,600	87,300	84,100	81,200	78,300	75,800	73,300	71,000	68,800	66,700	64,700	62,500
		Sensible	74,000	71,800	69,900	68,100	66,600	65,200	64,100	63,200	62,400	61,900	61,400	61,300
	80/67°F 26.6/19.4°C	Total	96,700	95,100	93,400	91,800	90,000	88,300	86,500	84,700	82,800	80,900	78,900	76,500
		Sensible	71,800	70,400	69,200	68,100	67,200	66,400	65,800	65,300	64,900	64,800	64,700	64,900
	85/72°F 29.4/22.2°C	Total	115,200	111,200	107,200	103,600	100,000	96,600	93,200	90,100	87,000	84,000	81,100	77,800
		Sensible	73,500	71,400	69,500	67,600	65,900	64,200	62,700	61,200	59,800	58,500	57,200	55,900
W120A	75/62°F 23.8/16.6°C	Total	139,100	129,500	121,100	113,700	107,100	101,500	96,700	92,800	89,500	87,100	85,300	84,200
		Sensible	109,800	103,900	98,800	94,400	90,600	87,500	85,100	83,200	81,800	81,100	81,000	81,700
	80/67°F 26.6/19.4°C	Total	148,500	141,200	134,500	128,500	123,000	118,300	114,200	110,700	107,800	105,600	104,000	103,000
		Sensible	106,500	101,900	97,900	94,400	91,500	89,100	87,300	86,000	85,200	85,000	85,300	86,500
	85/72°F 29.4/22.2°C	Total	176,800	165,000	154,400	145,000	136,600	129,400	123,100	117,700	113,200	109,700	106,900	104,800
		Sensible	109,000	103,400	98,300	93,700	89,700	86,200	83,200	80,600	78,400	76,800	75,400	74,400
W150A	75/62°F 23.8/16.6°C	Total	148,800	143,000	137,400	132,100	127,100	122,300	117,700	113,300	109,000	105,000	101,000	96,600
		Sensible	116,700	113,800	110,900	108,300	105,600	103,000	100,500	98,200	95,800	93,600	91,300	88,700
	80/67°F 26.6/19.4°C	Total	158,900	155,900	152,700	149,400	146,000	142,500	138,900	135,200	131,300	127,300	123,200	118,200
		Sensible	113,200	111,600	109,900	108,300	106,600	104,900	103,200	101,500	99,700	98,000	96,200	94,000
	85/72°F 29.4/22.2°C	Total	189,200	182,200	175,300	168,600	162,100	155,800	149,700	143,800	137,900	132,200	126,700	120,200
		Sensible	115,900	113,200	110,400	107,500	104,500	101,400	98,300	95,100	91,800	88,500	85,100	80,900
W180B	75/62°F 23.8/16.6°C	Total	189,800	179,900	170,800	162,500	154,900	148,100	142,000	136,400	131,400	127,000	123,200	119,300
		Sensible	148,400	143,500	139,000	134,700	130,900	127,500	124,300	121,500	119,000	116,800	115,000	113,100
	80/67°F 26.6/19.4°C	Total	202,700	196,100	189,800	183,800	178,000	172,700	167,600	162,800	158,300	154,100	150,200	146,000
		Sensible	144,000	140,700	137,700	134,800	132,200	129,800	127,600	125,700	123,900	122,400	121,100	119,800
	85/72°F 29.4/22.2°C	Total	241,400	229,200	217,900	207,400	197,600	188,800	180,600	173,100	166,300	160,000	154,400	148,500
		Sensible	147,400	142,700	138,300	133,800	129,600	125,500	121,500	117,800	114,000	110,500	107,100	103,100

- Notes:
- 1000 BTUH = .29307 kW
  - Outdoor air temperatures provided are an average of the condenser inlet air temperature.
  - Stage 1 Capacity approximately 35% of provided data.
  - Stage 2 Capacity approximately 80% of provided data.
  - Stage 3 Capacity is 100% of provided data.



////// **Cooling Application Data at High Sensible Airflow - Full Load Stage 3 - 60Hz Operation**

MODEL	RETURN AIR (DB/WB)	COOLING CAPACITY	Outdoor Temperature										
			75°F 23.9°C	80°F 26.6°C	85°F 29.4°C	90°F 32.2°C	95°F 35°C	100°F 37.7°C	105°F 40.5°C	110°F 43.3°C	115°F 46.1°C	120°F 48.8°C	125°F 51.6°C
W090A	75/62°F 23.8/16.6°C	Total	87,700	87,700	87,700	87,700	87,700	86,300	85,000	83,600	82,200	80,800	79,500
		Sensible	79,800	79,700	79,600	79,500	79,300	78,800	78,200	77,700	77,100	76,600	76,000
	80/67°F 26.6/19.4°C	Total	97,600	97,600	97,600	97,600	97,600	95,400	93,200	91,000	88,700	86,500	84,300
		Sensible	92,400	92,200	92,100	91,900	91,800	89,600	87,300	85,100	82,900	80,600	78,400
	85/72°F 29.4/22.2°C	Total	102,900	102,800	102,700	102,600	102,500	100,200	97,800	95,500	93,200	90,800	88,500
		Sensible	98,400	98,000	97,600	97,200	96,800	94,400	92,100	89,700	87,300	85,000	82,600
W120A	75/62°F 23.8/16.6°C	Total	131,700	128,900	126,000	123,100	120,300	116,100	112,000	107,900	103,800	99,700	95,500
		Sensible	115,000	113,300	111,600	109,900	108,200	105,700	103,200	100,700	98,200	95,800	93,300
	80/67°F 26.6/19.4°C	Total	133,600	130,700	127,800	124,900	122,000	119,700	117,500	115,200	113,000	110,700	108,400
		Sensible	123,500	121,700	119,900	118,000	116,200	113,600	111,000	108,400	105,800	103,300	100,700
	85/72°F 29.4/22.2°C	Total	140,400	138,700	136,900	135,200	133,400	130,900	128,500	126,000	123,500	121,100	118,600
		Sensible	132,100	130,300	128,500	126,600	124,800	122,000	119,300	116,500	113,700	110,900	108,100
W150A	75/62°F 23.8/16.6°C	Total	145,000	143,700	142,400	141,100	139,800	137,000	134,200	131,400	128,600	125,800	123,000
		Sensible	131,600	130,300	128,900	127,600	126,200	123,700	121,100	118,600	116,100	113,600	111,000
	80/67°F 26.6/19.4°C	Total	162,700	161,200	159,700	158,300	156,800	152,500	148,100	143,700	139,400	135,000	130,700
		Sensible	145,100	143,600	142,100	140,600	139,100	135,600	132,000	128,400	124,800	121,200	117,600
	85/72°F 29.4/22.2°C	Total	173,600	171,800	169,900	168,000	166,100	161,500	156,900	152,300	147,700	143,000	138,400
		Sensible	155,100	153,300	151,500	149,700	147,900	144,100	140,300	136,500	132,700	128,900	125,100
W180B	75/62°F 23.8/16.6°C	Total	195,100	183,900	173,800	164,800	156,600	149,500	143,200	137,800	133,200	129,300	126,100
		Sensible	157,100	151,900	147,200	142,900	139,000	135,500	132,400	129,700	127,300	125,200	123,500
	80/67°F 26.6/19.4°C	Total	208,400	200,500	193,100	186,300	180,000	174,300	169,100	164,500	160,400	156,900	153,800
		Sensible	152,400	149,000	145,900	143,000	140,400	138,000	135,900	134,100	132,500	131,200	130,100
	85/72°F 29.4/22.2°C	Total	248,200	234,300	221,700	210,200	199,900	190,600	182,200	174,900	168,500	162,900	158,100
		Sensible	156,000	151,100	146,500	142,000	137,600	133,400	129,400	125,600	122,000	118,400	115,000

- Notes:
- 1000 BTUH = .29307 kW
  - Outdoor air temperatures provided are an average of the condenser inlet air temperature.
  - Stage 1 Capacity approximately 35% of provided data.
  - Stage 2 Capacity approximately 80% of provided data.
  - Stage 3 Capacity is 100% of provided data.



**////// Cooling Application Data at Rated Airflow - Full Load Stage 3 - 50Hz Operation**

MODEL STAGE	RETURN AIR (DB/WB) C°	COOLING CAPACITY	23.8°C	26.6°C	29.4°C	32.2°C	35°C	37.7°C	40.5°C	43.3°C	46.1°C	48.8°C	51.6°C	55.0°C
W090A	23.8/16.6	Total Cooling Sensible Cooling	23.88 kW 19.54 kW	23.29 kW 19.16 kW	22.65 kW 18.84 kW	22 kW 18.49 kW	21.36 kW 18.17 kW	20.74 kW 17.84 kW	20.07 kW 17.52 kW	19.4 kW 17.23 kW	18.66 kW 16.94 kW	17.99 kW 16.64 kW	17.26 kW 16.38 kW	16.38 kW 16.09 kW
	26.6/19.4	Total Cooling Sensible Cooling	25.49 kW 18.96 kW	25.37 kW 18.78 kW	25.17 kW 18.66 kW	24.91 kW 18.49 kW	24.55 kW 18.34 kW	24.14 kW 18.17 kW	23.67 kW 17.99 kW	23.12 kW 17.81 kW	22.5 kW 17.64 kW	21.8 kW 17.46 kW	21.04 kW 17.26 kW	20.04 kW 17.05 kW
	29.4/22.2	Total Cooling Sensible Cooling	30.38 kW 19.4 kW	29.65 kW 19.05 kW	28.89 kW 18.72 kW	28.1 kW 18.37 kW	27.28 kW 17.99 kW	26.4 kW 17.58 kW	25.49 kW 17.14 kW	24.61 kW 16.7 kW	23.65 kW 16.26 kW	22.65 kW 15.76 kW	21.65 kW 15.27 kW	20.39 kW 14.68 kW
W120A	23.8/16.6	Total Cooling Sensible Cooling	37.09 kW 29.3 kW	34.54 kW 27.72 kW	32.32 kW 26.37 kW	30.33 kW 25.2 kW	28.57 kW 24.17 kW	27.07 kW 23.35 kW	25.78 kW 22.71 kW	24.76 kW 22.21 kW	23.88 kW 21.83 kW	23.23 kW 21.65 kW	22.77 kW 21.62 kW	22.47 kW 21.8 kW
	26.6/19.4	Total Cooling Sensible Cooling	39.61 kW 28.42 kW	37.65 kW 27.19 kW	35.86 kW 26.11 kW	34.28 kW 25.2 kW	32.82 kW 24.41 kW	31.56 kW 23.76 kW	30.47 kW 23.29 kW	29.53 kW 22.94 kW	28.74 kW 22.74 kW	28.16 kW 22.68 kW	27.75 kW 22.77 kW	27.48 kW 23.09 kW
	29.4/22.2	Total Cooling Sensible Cooling	47.14 kW 29.07 kW	44.01 kW 27.57 kW	41.2 kW 26.22 kW	38.68 kW 24.99 kW	36.45 kW 23.94 kW	34.52 kW 23 kW	32.85 kW 22.21 kW	31.41 kW 21.51 kW	30.21 kW 20.92 kW	29.27 kW 20.48 kW	28.51 kW 20.13 kW	27.95 kW 19.87 kW
W150A	23.8/16.6	Total Cooling Sensible Cooling	39.7 kW 31.53 kW	38.15 kW 30.74 kW	36.65 kW 29.94 kW	35.25 kW 29.18 kW	33.9 kW 28.45 kW	32.61 kW 27.72 kW	31.41 kW 26.99 kW	30.24 kW 26.31 kW	29.07 kW 25.64 kW	28.01 kW 24.99 kW	26.96 kW 24.35 kW	25.78 kW 23.62 kW
	26.6/19.4	Total Cooling Sensible Cooling	42.37 kW 30.59 kW	41.58 kW 30.15 kW	40.73 kW 29.65 kW	39.85 kW 29.18 kW	38.94 kW 28.71 kW	38 kW 28.22 kW	37.04 kW 27.72 kW	36.07 kW 27.22 kW	35.01 kW 26.69 kW	33.96 kW 26.19 kW	32.87 kW 25.67 kW	31.53 kW 25.02 kW
	29.4/22.2	Total Cooling Sensible Cooling	50.45 kW 31.32 kW	48.61 kW 30.56 kW	46.76 kW 29.8 kW	44.98 kW 28.98 kW	43.25 kW 28.16 kW	41.55 kW 27.28 kW	39.94 kW 26.4 kW	38.35 kW 25.49 kW	36.77 kW 24.58 kW	35.28 kW 23.67 kW	33.78 kW 22.71 kW	32.05 kW 21.54 kW
W180B	23.8/16.6	Total Cooling Sensible Cooling	50.63 kW 39.58 kW	47.99 kW 38.27 kW	45.56 kW 37.06 kW	43.33 kW 35.92 kW	41.31 kW 34.93 kW	39.5 kW 34.02 kW	37.88 kW 33.17 kW	36.39 kW 32.41 kW	35.04 kW 31.73 kW	33.87 kW 31.15 kW	32.87 kW 30.68 kW	31.82 kW 30.18 kW
	26.6/19.4	Total Cooling Sensible Cooling	54.06 kW 38.41 kW	52.3 kW 37.53 kW	50.63 kW 36.74 kW	49.02 kW 35.95 kW	47.47 kW 35.28 kW	46.06 kW 34.63 kW	44.71 kW 34.05 kW	43.42 kW 33.52 kW	42.22 kW 33.05 kW	41.11 kW 32.64 kW	40.05 kW 32.32 kW	38.94 kW 31.97 kW
	29.4/22.2	Total Cooling Sensible Cooling	64.37 kW 39.32 kW	61.12 kW 38.06 kW	58.1 kW 36.89 kW	55.32 kW 35.69 kW	52.71 kW 34.57 kW	50.37 kW 33.49 kW	48.17 kW 32.41 kW	46.18 kW 31.41 kW	44.36 kW 30.41 kW	42.66 kW 29.48 kW	41.2 kW 28.57 kW	39.61 kW 27.51 kW

**////// Cooling Application Data at High Sensible Airflow - Full Load Stage 3 - 50Hz Operation**

MODEL STAGE	RETURN AIR (DB/WB) C°	COOLING CAPACITY	23.8°C	26.6°C	29.4°C	32.2°C	35°C	37.7°C	40.5°C	43.3°C	46.1°C	48.8°C	51.6°C
W090A	23.8/16.6	Total Cooling Sensible Cooling	23.38 kW 21.27 kW	23.38 kW 21.24 kW	23.38 kW 21.21 kW	23.38 kW 21.18 kW	23.38 kW 21.15 kW	23.03 kW 21.01 kW	22.65 kW 20.86 kW	22.3 kW 20.72 kW	21.92 kW 20.57 kW	21.56 kW 20.42 kW	21.18 kW 20.28 kW
	26.6/19.4	Total Cooling Sensible Cooling	26.02 kW 24.64 kW	26.02 kW 24.58 kW	26.05 kW 24.55 kW	26.05 kW 24.52 kW	26.05 kW 24.47 kW	25.43 kW 23.88 kW	24.85 kW 23.29 kW	24.26 kW 22.68 kW	23.65 kW 22.09 kW	23.06 kW 21.51 kW	22.47 kW 20.89 kW
	29.4/22.2	Total Cooling Sensible Cooling	27.45 kW 26.22 kW	27.42 kW 26.14 kW	27.4 kW 26.02 kW	27.37 kW 25.9 kW	27.34 kW 25.81 kW	26.72 kW 25.17 kW	26.08 kW 24.55 kW	25.46 kW 23.91 kW	24.85 kW 23.29 kW	24.2 kW 22.65 kW	23.59 kW 22.03 kW
W120A	23.8/16.6	Total Cooling Sensible Cooling	35.13 kW 30.68 kW	34.37 kW 30.21 kW	33.61 kW 29.74 kW	32.82 kW 29.3 kW	32.05 kW 28.83 kW	30.97 kW 28.19 kW	29.86 kW 27.51 kW	28.77 kW 26.87 kW	27.66 kW 26.19 kW	26.58 kW 25.52 kW	25.46 kW 24.88 kW
	26.6/19.4	Total Cooling Sensible Cooling	35.63 kW 32.93 kW	34.87 kW 32.46 kW	34.08 kW 31.97 kW	33.31 kW 31.47 kW	32.52 kW 30.97 kW	31.94 kW 30.3 kW	31.32 kW 29.59 kW	30.71 kW 28.92 kW	30.12 kW 28.22 kW	29.51 kW 27.54 kW	28.92 kW 26.84 kW
	29.4/22.2	Total Cooling Sensible Cooling	37.45 kW 35.22 kW	36.98 kW 34.72 kW	36.51 kW 34.25 kW	36.04 kW 33.75 kW	35.57 kW 33.28 kW	34.9 kW 32.55 kW	34.25 kW 31.79 kW	33.58 kW 31.06 kW	32.93 kW 30.33 kW	32.29 kW 29.56 kW	31.61 kW 28.83 kW
W150A	23.8/16.6	Total Cooling Sensible Cooling	38.65 kW 35.1 kW	38.32 kW 34.72 kW	37.97 kW 34.37 kW	37.62 kW 34.02 kW	37.27 kW 33.64 kW	36.54 kW 32.96 kW	35.78 kW 32.29 kW	35.04 kW 31.61 kW	34.28 kW 30.94 kW	33.55 kW 30.27 kW	32.82 kW 29.59 kW
	26.6/19.4	Total Cooling Sensible Cooling	43.36 kW 38.71 kW	42.98 kW 38.3 kW	42.6 kW 37.88 kW	42.19 kW 37.5 kW	41.81 kW 37.09 kW	40.64 kW 36.16 kW	39.5 kW 35.19 kW	38.32 kW 34.22 kW	37.15 kW 33.28 kW	36.01 kW 32.32 kW	34.84 kW 31.38 kW
	29.4/22.2	Total Cooling Sensible Cooling	46.29 kW 41.34 kW	45.8 kW 40.87 kW	45.3 kW 40.4 kW	44.8 kW 39.94 kW	44.3 kW 39.44 kW	43.07 kW 38.44 kW	41.84 kW 37.42 kW	40.61 kW 36.39 kW	39.38 kW 35.39 kW	38.15 kW 34.37 kW	36.92 kW 33.34 kW
W180B	23.8/16.6	Total Cooling Sensible Cooling	52.04 kW 41.9 kW	49.05 kW 40.52 kW	46.35 kW 39.26 kW	43.95 kW 38.12 kW	41.78 kW 37.06 kW	39.88 kW 36.16 kW	38.21 kW 35.31 kW	36.74 kW 34.6 kW	35.54 kW 33.96 kW	34.49 kW 33.4 kW	33.64 kW 32.93 kW
	26.6/19.4	Total Cooling Sensible Cooling	55.58 kW 40.64 kW	53.47 kW 39.73 kW	51.51 kW 38.91 kW	49.69 kW 38.15 kW	47.99 kW 37.45 kW	46.5 kW 36.8 kW	45.09 kW 36.24 kW	43.86 kW 35.78 kW	42.78 kW 35.34 kW	41.84 kW 34.98 kW	41.02 kW 34.69 kW
	29.4/22.2	Total Cooling Sensible Cooling	66.19 kW 41.61 kW	62.5 kW 40.32 kW	59.13 kW 39.09 kW	56.05 kW 37.88 kW	53.33 kW 36.71 kW	50.84 kW 35.57 kW	48.61 kW 34.52 kW	46.65 kW 33.49 kW	44.95 kW 32.55 kW	43.59 kW 31.59 kW	42.16 kW 30.68 kW

- Notes:
- 1000 BTUH = .29307 kW
  - Outdoor air temperatures provided are an average of the condenser inlet air temperature.
  - Stage 1 part load operation reduces cooling capacity to approximately 35% of provided data.
  - Stage 2 part load operation reduces cooling capacity to approximately 80% of provided data.
  - Stage 3 full load operation is 100% of provided data.



////// Electrical Specifications: W090, W120, W150, W180 Units Without Electric Reheat

Volt - Phase	Unit Model	Heater Package	Number of Power Circuits	Single Circuit		Dual or Triple Circuit						
				Min. Circuit Ampacity (MCA)	Max. Operating Circuit Protection (MOCP)	Min. Circuit Ampacity (MCA)			Max. Operating Circuit Protection (MOCP)			
						Ckt. A	Ckt. B	Ckt. C	Ckt. A	Ckt. B	Ckt. C	
B - 208/230V-60-3, E - 200V/220V-50-3 S - 208/230V-60-3, 200V/220V-50-3	W090APB W090APE	OZ	1	46	60							
		09	1	46	60							
		18	1	59	60							
	W120APB W120APE	OZ	1 or 2	56	70	32	25		40	40		
		09	1 or 2	56	70	32	28		40	40		
		18	1 or 2	59	70	32	28		40	40		
	W150APB W150APE	OZ	1 or 2	67	80	39	34		50	40		
		09	1 or 2	67	80	39	34		50	40		
		18	1 or 2	67	80	39	34		50	40		
	W180BPS	OZ	1 or 2	85	100	54	32		60	50		
		09	1 or 2	85	100	54	32		60	50		
		18	1 or 2	85	100	54	32		60	50		
		36	1 or 3	115	125	54	55	55	60	60	60	
	C - 460V-60-3, V - 415V-50-3 T - 460V-60-3, 415V-50-3	W090APC W090APV	OZ	1	21	30						
			09	1	21	30						
			18	1	30	35						
W120APC W120APV		OZ	1	27	40							
		09	1	27	40							
		18	1	30	40							
W150APC W150APV		OZ	1	32	40							
		09	1	32	40							
		18	1	32	40							
W180BPT		OZ	1	40	60							
		09	1	40	60							
		18	1	40	60							
	36	1	58	60								
Q - 575V-60-3	W090APQ	OZ	1	19	25							
		09	1	19	25							
		18	1	25	30							
	W120APQ	OZ	1	24	35							
		09	1	24	35							
		18	1	27	35							
	W150APQ	OZ	1	24	35							
		09	1	24	35							
		18	1	30	35							
	W180BPQ	OZ	1	31	45							
		09	1	31	45							
		18	1	31	45							
36		1	48	50								
N - 400V-60-3	W120APN	OZ	1	32	40							
		09	1	32	40							
		18	1	32	40							
	W150APN	OZ	1	34	40							
		09	1	34	40							
		18	1	34	40							
	W180BPN	OZ	1	47	60							
		09	1	47	60							
		18	1	47	60							
		36	1	51	60							

- ① Maximum size of the time delay fuse or circuit breaker for protection of field wiring conductors.
- ② Based on 75°C copper wire. All wiring must conform to the National Electrical Code and all local codes.
- ③ These "Minimum Circuit Ampacity" values are to be used for sizing the field power conductors. Refer to the National Electrical code (latest version), Article 310 for power conductor sizing.

**CAUTION:** When more than one field power circuit is run through one conduit, the conductors must be derated. Pay special attention to Note 8 of Table 310 regarding Ampacity Adjustment Factors when more than three current carrying conductors are in a raceway.

**IMPORTANT:** While this electrical data is presented as a guide, it is important to electrically connect properly sized fuses and conductor wires in accordance with the National Electrical Code and all local codes.

Note: MOCP (Maximum Overcurrent Protection) value listed is the maximum value as per UL 1995 calculations for MOCP (branch-circuit conductor sizes in this chart are based on this MOCP). The actual factory installed Overcurrent Protective Device (Circuit Breaker) in this model may be lower than the maximum UL 1995 allowable MOCP value, but still above the UL 1995 minimum calculated value or Minimum Circuit Ampacity (MCA) listed.



/////// **Electrical Specifications: W090, W120, W150, W180 Units With Electric Reheat**

Volt - Phase	Unit Model	Heater Package	Number of Power Circuits	Single Circuit		Dual or Triple Circuit					
				Min. Circuit Ampacity (MCA)	Max. Operating Circuit Protection (MOCP)	Min. Circuit Ampacity (MCA)			Max. Operating Circuit Protection (MOCP)		
						Ckt. A	Ckt. B	Ckt. C	Ckt. A	Ckt. B	Ckt. C
B - 208/230V-60-3, E - 200V/220V-50-3 S - 208/230V-60-3, 200V/220V-50-3	W090AEB W090AEE	18	1 or 2	100	100	56	46		60	50	
	W120AEB W120AEE	18	1 or 2	110	120	59	52		60	60	
	W150AEB W150AEE	18	1 or 2	120	125	59	55		60	60	
	W180BES	18	1 or 2	140	150	54	59	28	60	60	30
C - 460V-60-3, V - 415V-50-3 T - 460V-60-3, 415V-50-3	W090AEC W090AEV	18	1	53	60	Note: MOCP (Maximum Overcurrent Protection) value listed is the maximum value as per UL 1995 calculations for MOCP (branch-circuit conductor sizes in this chart are based on this MOCP). The actual factory installed Overcurrent Protective Device (Circuit Breaker) in this model may be lower than the maximum UL 1995 allowable MOCP value, but still above the UL 1995 minimum calculated value or Minimum Circuit Ampacity (MCA) listed.  Units with electric reheat are sized to allow the compressors and electric heat to run concurrently. All units with the electric reheat option are supplied with 18kw electric heat kits.					
	W120AEC W120AEV	18	1	54	60						
	W150AEC W150AEV	18	1	58	60						
	W180BET	18	2			54	14		60	20	
Q - 575V-60-3	W090AEQ	18	1	42	45	① Maximum size of the time delay fuse or circuit breaker for protection of field wiring conductors. ② Based on 75°C copper wire. All wiring must conform to the National Electrical Code and all local codes. ③ These "Minimum Circuit Ampacity" values are to be used for sizing the field power conductors. Refer to the National Electrical code (latest version), Article 310 for power conductor sizing.  <b>CAUTION:</b> When more than one field power circuit is run through one conduit, the conductors must be derated. Pay special attention to Note 8 of Table 310 regarding Ampacity Adjustment Factors when more than three current carrying conductors are in a raceway.  <b>IMPORTANT:</b> While this electrical data is presented as a guide, it is important to electrically connect properly sized fuses and conductor wires in accordance with the National Electrical Code and all local codes.					
	W120AEQ	18	1	46	50						
	W150AEQ	18	1	47	50						
	W180BEQ	18	1	53	60						
N - 400V-60-3	W120AEN	18	1	56	60						
	W150AEN	18	1	57	60						
	W180BEN	18	2			59	12		60	20	



//////// **Electric Heat Table - Refer to Electrical Specifications for Availability by Unit Model**

Nominal Heater Kw Listed Per Unit Model	Actual Unit Voltage																	
	AT 208V-3ph-60hz.			AT 240V-3ph-60hz.			AT 400V-3ph-60hz.			AT 460V-3ph-60hz.			AT 480V-3ph-60hz.			AT 575V-3ph-60hz.		
	KW	AMPS	BTUH	KW	AMPS	BTUH	KW	AMPS	BTUH	KW	AMPS	BTUH	KW	AMPS	BTUH	KW	AMPS	BTUH
9.00	6.75	18.70	23,038	9.00	21.70	30,717	7.50	9.00	25,598	8.28	10.40	28,260	9.00	10.80	30,717	9.00	9.02	30,717
18.00	13.50	37.50	46,076	18.00	43.30	61,434	15.00	18.08	51,195	16.56	20.80	56,519	18.00	21.70	61,434	18.00	18.11	61,434
36.00	27.00	75.00	92,152	36.00	86.60	122,868	30.00	36.17	102,390	33.12	41.60	113,038	36.00	43.40	122,868	36.00	36.23	122,868

Nominal Heater Kw Listed Per Unit Model	Actual Unit Voltage											
	AT 200V-3ph-50hz.			AT 220V-3ph-50hz.			AT 380V-3ph-50hz.			AT 415V-3ph-50hz.		
	KW	AMPS	BTUH	KW	AMPS	BTUH	KW	AMPS	BTUH	KW	AMPS	BTUH
9.00	6.49	17.98	22,152	8.25	19.89	28,157	7.13	8.55	24,318	7.47	9.38	25,495
18.00	12.98	36.06	44,304	16.50	39.69	56,315	14.25	17.18	48,635	14.94	18.77	50,990
36.00	25.96	72.12	88,608	33.00	79.38	112,629	28.50	34.36	97,271	29.88	37.53	101,980

//////// **MEGA-TEC Ventilation Option Selection Chart**

Vent Code	Vent Type	Description
B	No Ventilation	Unit does not include intake or exhaust openings for ventilation.
E	Economizer	Free flow economizer. Enthalpy, Dew Point, or Dry Bulb economizing settings. A field installed 7" hood is required on each side of the unit. The economizer is not a field installed option.

\* Note: Ventilation options are not field installable.

**“B” Vent Code Option – No Vent**

This unit is constructed without the economizer vent option and the air intake and exhaust openings are removed. The no vent option may be utilized when outside air intake is not desired or required by local codes.

**“E” Vent Code Option – Free Cooling Economizer**

The free cooling economizer uses multiple 2-10V High torque actuators to independently control each intake and exhaust damper. Outdoor intake air enters the left and right sides of the unit through intake hoods. Intake air is pre-filtered before entering the unit. Room air is exhausted using one or more separate dampers into the condenser section partition of the unit. A large exhaust air path is provided to reduce room pressure to slight positive pressurization during economizer operation. All dampers include rubber seals for positive shutoff when the economizer is not being operated.

All operation is controlled by the unit logic board. Magnetic proximity sensors attached to each economizer blade indicate a damper failure. A dust sensor is provided to monitor particulates in the outdoor air being brought into the structure, and disable economizer use when the particulate level is too high. Outdoor temperature/humidity conditions are monitored through a sensor located on the side of the unit.

**Unit Software Economizer Features:**

- Standard dry bulb outdoor temperature control of economizer operation.
- Optional wet bulb outdoor enthalpy control of economizer operation. Enthalpy measured in either %RH or Dew point.
- Passive Dehum: Economizer operation can be disabled if humidity levels measured by the LC6000 reach the indoor maximum humidity set point. The default passive indoor humidity set point is 70%RH\*.
- Emergency Vent: When NO/NC\* contacts are energized in the LC6000, the economizer blades are fully opened and the evaporator Fan is activated.
- Emergency Off: When NO/NC\* contacts are energized in the LC6000, the economizer blades are closed, and unit operation is disabled.
- Emergency Cool: When high temp alarm 2 is active in the LC6000 due to a High temperature event in a zone, the economizer blades are fully opened and the Evaporator Fan is activated.

\*Default setting.

**Note:** Fire suppression systems that use gases to flood an area may require economizer shutdown within 30 seconds of a smoke/fire event. A signal from the LC6000 controller to close all dampers and disable unit operation can take over a minute (time will vary based on daisy chain connections). A relay must be installed to break the 24VAC power supply output from the low voltage transformer in each unit in order to shorten the blade closure time and disable unit operation.



## ///// Indoor Standard Airflow @ Full Load Cooling Static Performance Curves

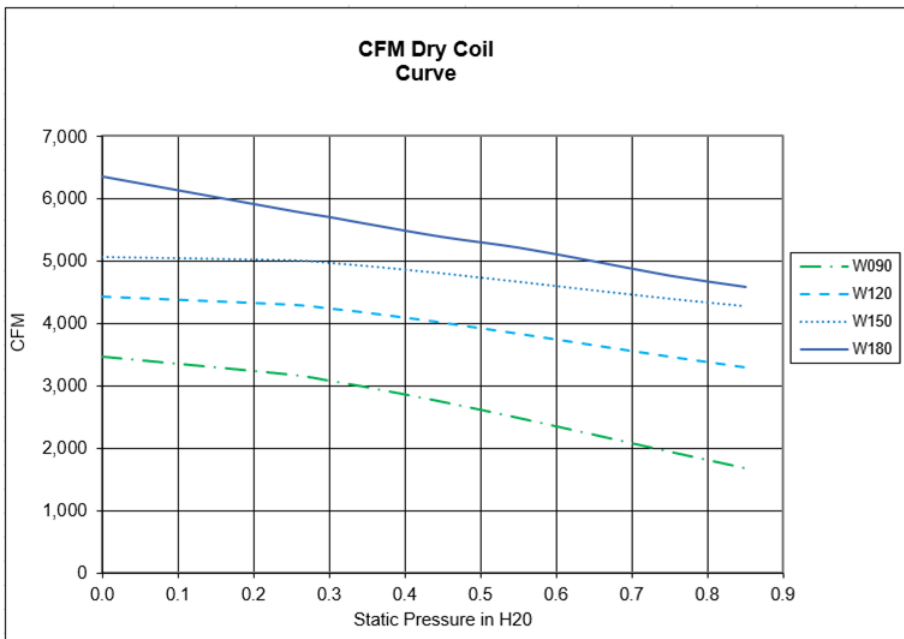

Total External Static Pressure Calculation:

$$\text{Supply Duct Static} + \text{Return Duct Static} + \text{Filter Static} + \text{Additional External Static} = \text{Total External Static Pressure (ESP)}$$

Total External Static Adjustment:

Indoor airflow data shown in the performance charts represent the unit with a dry coil and running in nominal (standard operation) Stage 3 full load cooling with a wet evaporator coil. A dry evaporator coil will provide less static.

Indoor airflow data shown in the performance charts represent the unit with a 2" disposable MERV8 filter. For other filter options, external static pressure needs to be adjusted. See adjustment factor in below table.

FILTER CODE	FILTER MERV RATING	ADJUST STATIC
M	MERV 11	+.05" WC
N	MERV 13	+.08" WC

MERV Filter Ratings:

Higher MERV rated filter provide additional filtration during each air exchange through the unit. However, the frequency of filter changes will be higher as the MERV rating increases due to the additional dirt, dust, and debris being trapped in the filter media. Always provide a good maintenance plan that includes filter changes based on the environment and air quality of the area being conditioned by the unit.

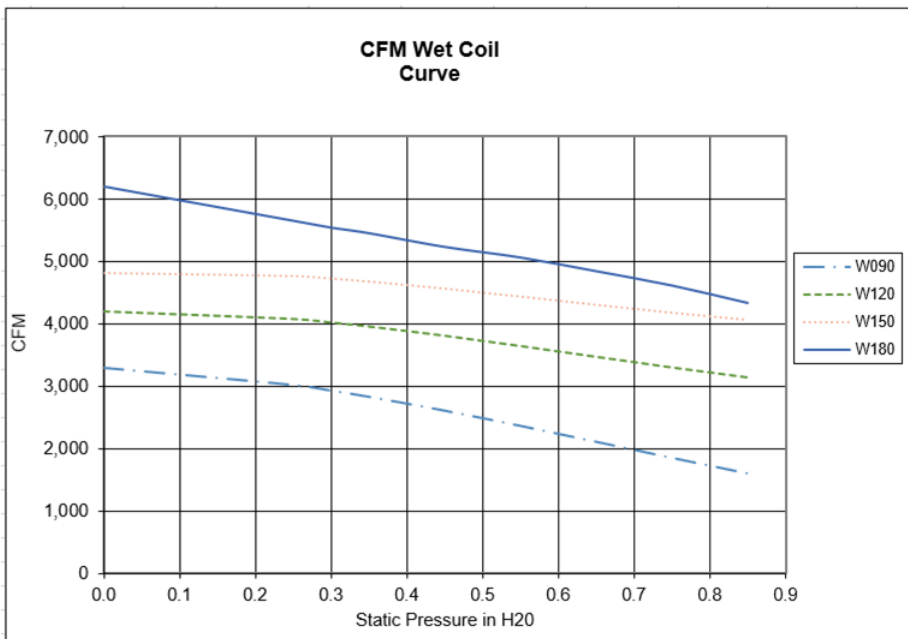

## ///// MEGA-TEC Filter Option Selection Chart

Filter Code	Filter Type	Dust Spot Efficiency	Arrestance	Particle Size Filtration	Description
P	MERV 8	30-35%	>90%	3 to 10 microns	2" pleated standard filtration.
M	MERV 11	60-65%	>95%	1 to 3 microns	2" pleated high filtration.
N	MERV 13	89-90%	>98%	.3 to 1 microns	2" pleated maximum filtration.



# //////// Indoor Airflow During Different Modes of Operation @ Rated Static with Wet Evaporator Coil

## Fan Only Operation

Fan only airflow occurs when continuous fan is energized. Cooling and heating operation is not energized. Minimum damper position may be used during continuous fan to bring in a slight amount of outdoor air with the fan energized.

## Economizer Free Cooling

Economizer free cooling airflow occurs when the economizer damper is open to provide cooling for the indoor space using outdoor air.

## Stage 1, 2, and 3 Balanced Climate Cooling

Balanced Climate airflow occurs when the Balanced Climate Feature is enabled in the Blower Configuration menu (Off by default) and a call for cooling is present. When enabled, Balanced Climate fan speed will be used based on the humidity setpoints adjusted in the LC6000 controller.

## Stage 1, 2, and 3 Standard Nominal Cooling

Standard nominal cooling airflow occurs when Balanced Climate or High Sensible cooling are not used, and the unit has a call for cooling.

## Stage 1, 2, and 3 High Sensible Cooling

High Sensible airflow occurs when the High Sensible Feature is enabled in the Blower Configuration menu (On by default) and a call for cooling is present. When enabled, High Sensible fan speed will be used based on the humidity setpoints adjusted in the LC6000 controller.

## 1st and 2nd Stage Electric Heat

Optional electric heat airflow is used when a heating call is present based on the heating setpoint. Electric heat must be ordered with the unit for electric heat operation.

## Electric Reheat Dehumidification

Optional electric reheat dehumidification airflow occurs when the MEGA-TEC unit is purchased with this feature and a call for active dehumidification is present. Electric Reheat fan speed will be used based on the humidity setpoints adjusted in the LC6000 controller.

## Emergency Ventilation

Emergency ventilation airflow occurs when an emergency ventilation signal is received from the LC6000 controller. By default, this fan speed is set at the maximum airflow available for the MEGA-TEC unit.

## Indoor Airflow Adjustment

See Service Instructions 2100-671 for airflow adjustment regarding W090, W120, and W150 MEGA-TEC unit models. See Service Instructions 2100-749 for airflow adjustment regarding W180 MEGA-TEC unit models.

Unit Operation	W090 Airflow CFM @.25 ESP	W120 Airflow CFM @.30 ESP	W150 Airflow CFM @.35 ESP	W180 Airflow CFM @.35 ESP
Fan Only	2500	2400	2300	3400
Economizer Free Cooling	3000	4000	4650	5400
Stage 1 Balanced Climate Cooling	1470	2000	2200	1750
Stage 2 and 3 Balanced Climate Cooling	2100	2800	3200	3360
Stage 1 Standard Nominal Cooling	2100	2800	3200	3400
Stage 2 and 3 Standard Nominal Cooling	3000	4000	4650	5400
Stage 1 High Sensible Cooling	2500	3300	3900	4380
Stage 2 and 3 High Sensible Cooling	3600	4400	5700	6100
Heating 1st Stage	4000	4000	4000	5400
Heating 2nd Stage	4000	4000	4000	5400
Electric Reheat Dehumidification	4000	4000	4000	3360
Emergency Ventilation	7700	7700	7700	8200



## /////// Cabinet Options

### Cabinet Finish Options

Unit models are available in Beige, White, Buckeye Gray, and Stainless Steel (W090, W120, W150 only). Painted cabinet construction is comprised of 16 gauge Zinc coated steel. Parts are cleaned, rinsed, sealed, and dried before a polyurethane primer is applied. The cabinet coating is completed with a baked on textured enamel. The resulting finish is designed to withstand 1000 hours of salt spray tests per ASTM B117-03.

Stainless steel external cabinet construction is comprised of 316 grade materials. Stainless steel screws and fasteners are used in all externally exposed areas. A enhanced corrosion resistant coated condenser fan assembly is provided with the stainless steel option.



## /////// Evaporator and Condenser Coil Coating Options

### Green Fin Hydrophilic Evaporator Coils Standard On All Units

Bard WALL MOUNT products include a green protective coating applied to the aluminum fin stock used for the evaporator coil. The evaporator coil coating is hydrophilic (attracts water) and allows for proper condensate drainage along with mild corrosion protection. Resistance to corrosive agents include ammonia, sodium hydroxide, sodium chloride, acidic solutions and solvents.

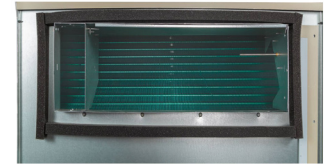

Hydrophilic Green Coil  
(standard)

### Evaporator (1) Condenser (2) or both Evaporator and Condenser (3) Coil Technicoat Coating Options

Bard now offers TECHNICOAT AA, a robust dipped coating option for the evaporator and condenser coil. TECHNICOAT AA has passed all HVAC accelerated tests like salt spray, flexibility and SWAAT 3,000+ hours. It has been tested in the field in the most severe industrial exposure conditions, such as a coastal refinery in Saudi Arabia, mining facilities in central Africa, and various Pacific islands. TECHNICOAT AA did not show any deterioration after multiple years of function with coils directly exposed to such harsh environmental conditions. The TECHNICOAT AA coating system is based on modified acrylic waterborne binders with high elongation properties. Aluminum pigmentation has been added to establish exceptional heat transfer, chemical resistance, and UV blocking properties. Corrosion resistance reaches >10,000+ hours in ASTM B-117 and >3,120 hours in SWAAT testing. Coating is gray in color.

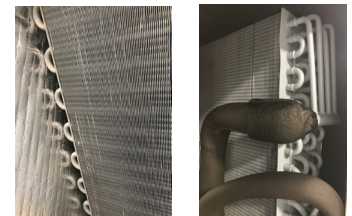

TechniCoat  
(optional)

## /////// Packaging Options Including Wood Skids, Metal Skids and Platforms, and Crates.

The MEGA-TEC® unit can be shipped using a standard wood skid, or can be ordered with a metal platform under the unit. The metal platform supports the unit resting on the ground after wall attachment. Optional crates are available to help protect your valuable MEGA-TEC® investment during shipping. Constructed from OSB sheathing with steel corner posts, and sized for standard truck transportation. Treated for pests in accordance with the International Plant Protection Convention, Publication 15, Annex 1. Packaging is acceptable for international shipments.

Packaging Code	Packaging Type for W090, W120, W150	Description
X	Wood Skid and Standard Packaging.	Unit ships on standard wood skid with stretch wrap, cardboard corners and top cap. The wood skid is 5" in height.
1	White Metal Platform and Std. Packaging.	Unit ships on a White 16 Ga. painted metal platform with stretch wrap, cardboard corners and top cap. The platform is 3.75" in height.
2	Wood Skid and Crate.	Unit ships on standard wood skid. A wood crate is installed over the standard packaging to protect the sides and top of the unit. The wood skid is 5" in height.
3	White Metal Platform and Crate.	Unit ships on a White 16 Ga. painted metal platform. A wood crate is installed over the standard packaging to protect the sides and top of the unit. The platform is 3.75" in height.
6	Gray Metal Platform and Std. Packaging.	Unit ships on a Gray 16 Ga. painted metal platform with stretch wrap, cardboard corners and top cap. The platform is 3.75" in height.
7	Gray Metal Platform and Crate.	Unit ships on a Gray 16 Ga. painted metal platform. A wood crate is installed over the standard packaging to protect the sides and top of the unit. The platform is 3.75" in height.

Packaging Code	Packaging Type for W180	Description
X	Metal Skid and Standard Packaging.	Unit ships on a 16 Ga. galvanized metal platform, cardboard corners and top cap. The platform is 4.5" in height.
1	Metal Skid and Crate.	Unit ships on a 16 Ga. galvanized metal platform. A wood crate is installed over the standard packaging to protect the sides and top of the unit. The platform is 4.5" in height.



## Condenser Section Easy Access

Access to compressors, filter-driers, the economizer exhaust damper motor/linkage, and evaporator drain hoses are behind the condenser fan. Access to the interior condenser section is also recommended for condenser coil cleaning. The condenser fan is on a sliding carriage for easy access to the interior of the condenser section. A safety switch is also installed in the condenser section. Follow all safety instructions provided in the unit installation and service manual provided with the MEGA-TEC®.



Slide out Condenser Fan

## Condenser Fan Specifications

The EC outdoor industrial fan assembly maintains its high efficiency across a wide operating range. Modbus allows accurate fan control by the unit logic board. The result is a significant reduction in energy use when the motor is ran at reduced speeds. The motor contains reverse polarity and locked motor protection. Aluminum blade sprayed with PP plastic. Steel grille coated with PP plastic. Fan has a black gloss paint finish.



Condenser Fan

SPECIFICATION	DESCRIPTION
DEGREE OF PROTECTION	IP55
MOISTURE/ENV. CLASS	F4-1
INSULATION CLASS	F
PROTECTION CLASS	1
EMC IMMUNITY	EN61000-6-2
WEIGHT	89lbs (40.2kg)

## Evaporator Fan Specifications

The EC indoor industrial fan assembly maintains its high efficiency across a wide operating range. Modbus allows accurate fan control by the unit logic board. The result is a significant reduction in energy use when the motor is operating at reduced speeds. The motor uses ball bearing construction, temperature protection, soft start, and an integrated PID controller. Aluminum impeller with steel frame construction for strength.

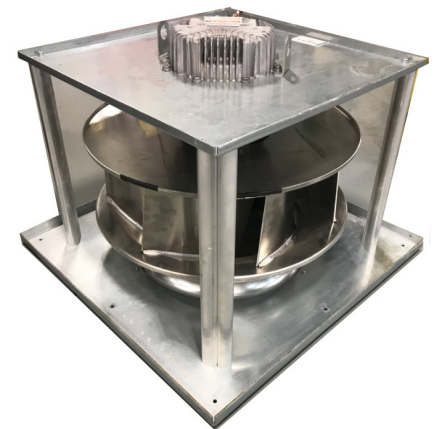

Evaporator Fan

SPECIFICATION	DESCRIPTION
DEGREE OF PROTECTION	IP55
MOISTURE/ENV. CLASS	F4-1
INSULATION CLASS	F
PROTECTION CLASS	1
EMC IMMUNITY	EN61000-6-2
WEIGHT	66lbs. (30kg)

## PLC Logic Board Specifications

Each unit uses a programmable logic board located in the unit control panel to communicate with the LC controller. By using a 2-wire connection, alarm functionality and unit operational commands are communicated. If communication is lost, the unit is able to run by using the logic in the unit controller in orphan mode.

SPECIFICATION	DESCRIPTION
POWER SUPPLY SPECS.	24Vac/Vdc +10%/-15% 50/60 Hz
MAX. POWER INPUT	28 VA
BATTERY TYPE	Lithium Battery, BR2032, 3VDC
BATTERY LIFE, USE	Minimum 8 years, Used for Date/Time Storage
TEC-EYE CONNECTION	J10 Telephone Connector
ETHERNET CONNECTION	CAT5 Connector, 325ft. (100m) Max. Wire Length
STORAGE CONDITIONS	-40°F to 158°F (-40°C to 70°C) 90%RH non-condensing
OPERATING CONDITIONS	-40°F to 140°F (-40°C to 60°C) 90%RH non-condensing

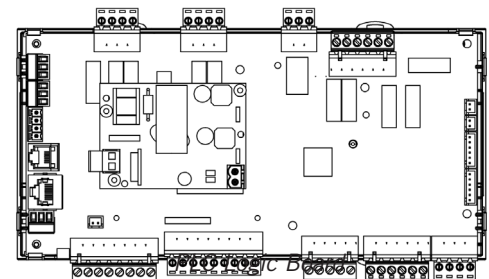

**/////// Cabinet Dimensions - W090, W120, W150 Series Units**

	Cabinet Width (W)	Cabinet Depth (D)	Cabinet Height (H)	Supply Height (A)	Supply Width (B)	Return Height (C)	Return Width (B)	E	F	G	I	K	L	M	N	O	P	R	S	T	U
Inch	50.64	43.19	94.22	15.81	42.74	21.82	42.74	54.24	12.27	34.95	25.98	28.65	23.73	21.48	11.68	52.24	19.48	2.73	16.00	11.49	67.65
cm	128.63	109.70	239.32	40.16	108.56	55.42	108.56	137.77	31.17	88.77	65.99	72.77	60.27	54.56	29.67	132.69	49.48	6.93	40.64	29.18	171.83

Notes: Electrical entrances are located on both sides of unit.  
 Side wall mounting brackets use Ø.500 wall mounting holes.  
 Top rain flashing ships attached to unit back, be sure to remove flashing before installing unit.  
 Top lifting plates ship with unit. See below for lift plate details. Follow all guidelines in installation instructions.

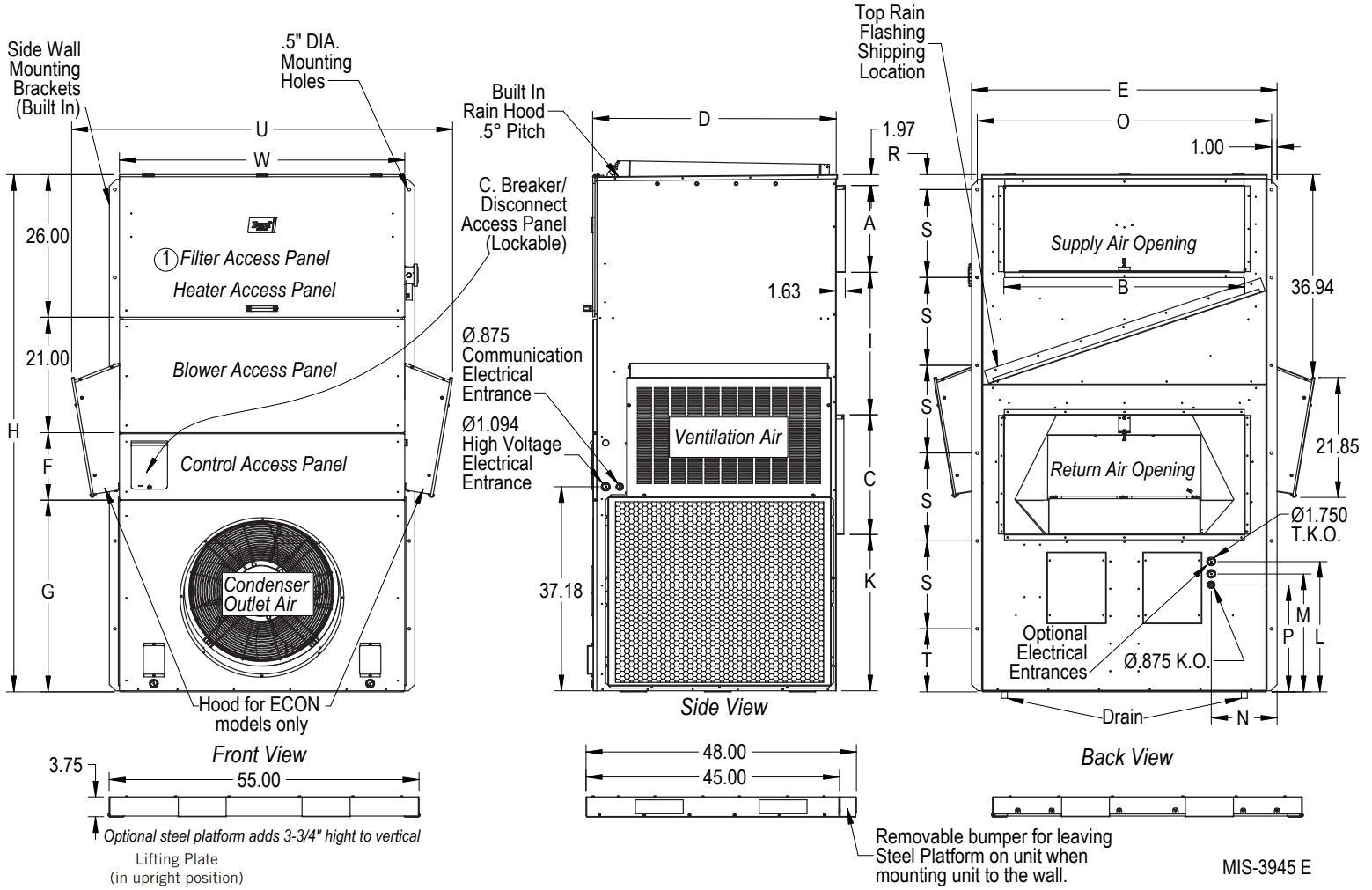

Removable bumper for leaving Steel Platform on unit when mounting unit to the wall. MIS-3945 E

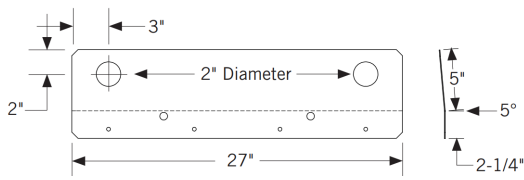
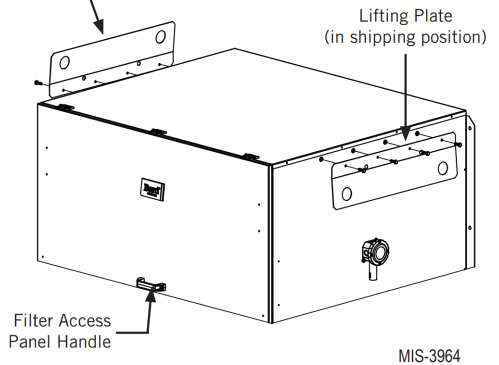

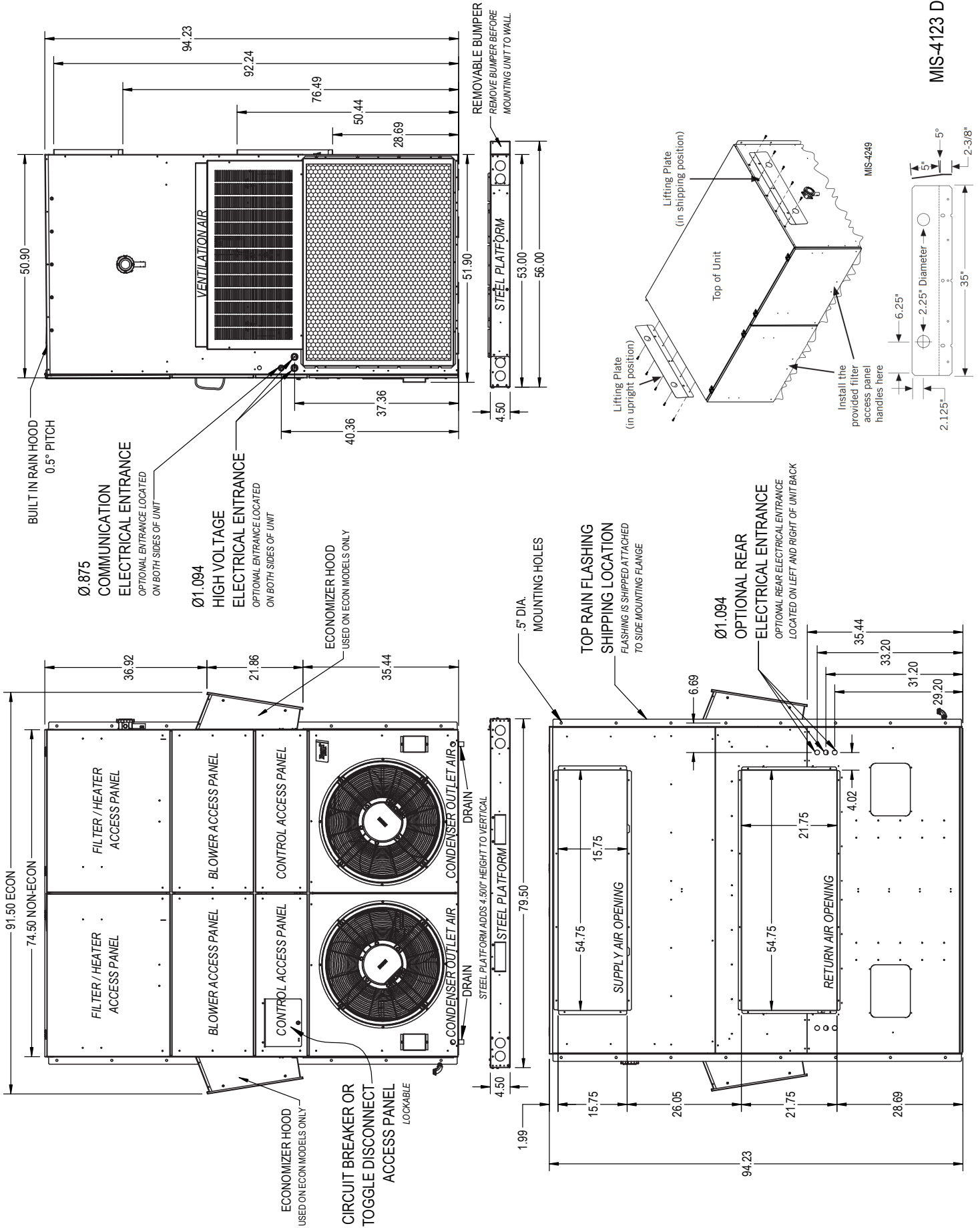

////// Clearance Dimensions for W090, W120, W150 Units

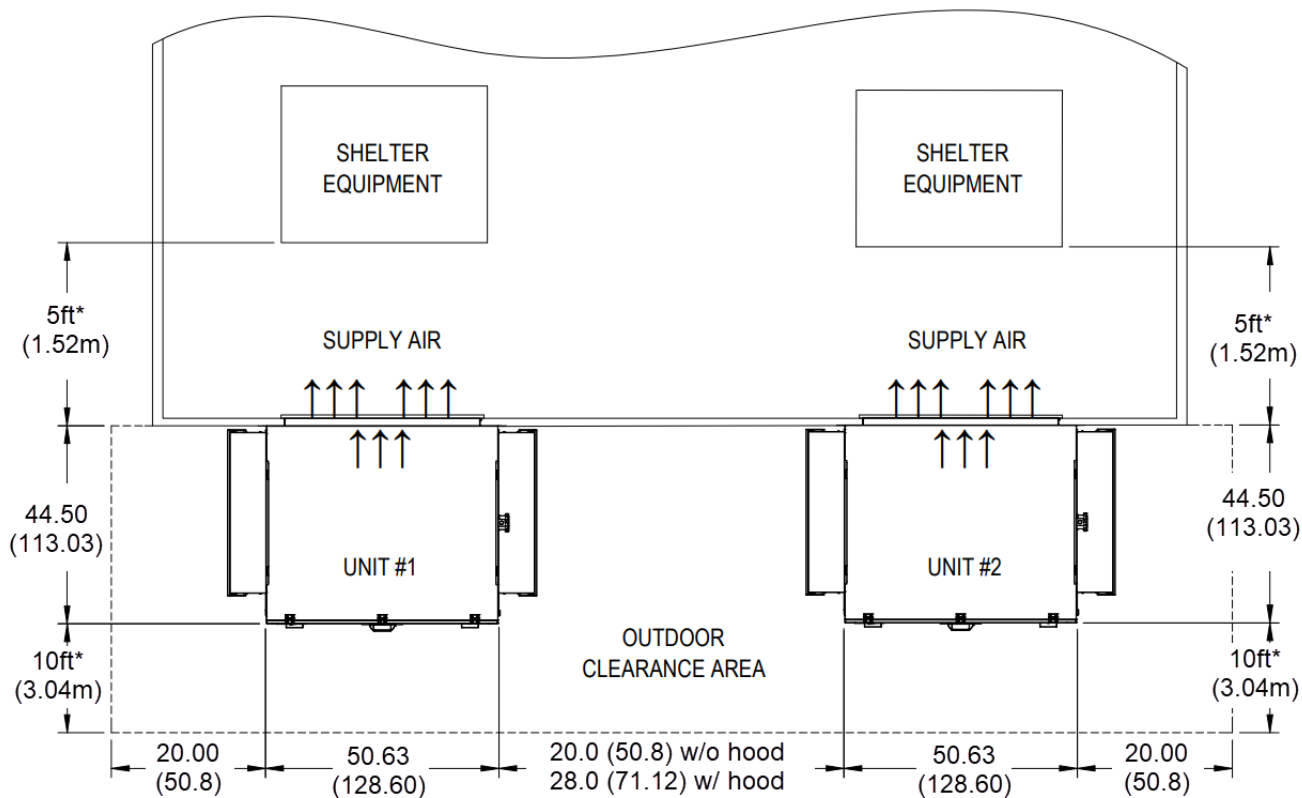

\* Recommended distance between return air opening and equipment in room. Supply airstream must be able to provide adequate air circulation throughout the room.

MIS-3962

All national, state and local codes must be observed and followed during installation.

////// Clearance Dimensions for W180 Units

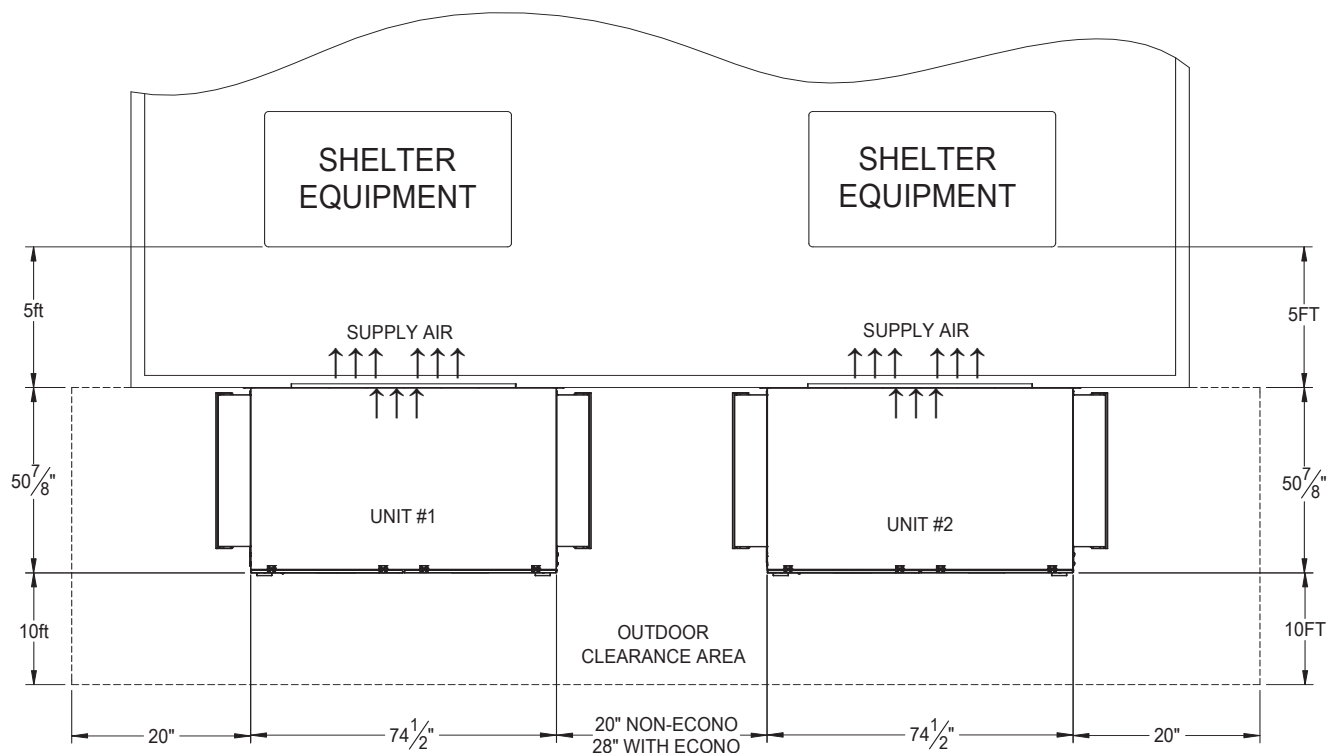

MIS-4255



////// **Factory Supplied Unit Components List**

Refrigerant Components	Function	Description
Compressor Refrigeration Left Circuit A	2 Stage R410A compressor	Scroll compressor used for left refrigeration circuit capable of running at 66% or 100% of compressor capacity.
Compressor Refrigeration Right Circuit B	1 Stage R410A compressor	Scroll compressor used for right refrigeration circuit capable of running at 100% of compressor capacity.
Crankcase Heater (CCH)	Compressor heating device	The heater is a belly band that is installed around the base of the compressor that applies heat when the refrigeration system is not operational. This heat is meant to prevent refrigerant oil migration when the unit is not running.
Electronic Expansion Valve (EEV)	Electronic Expansion Valve refrigerant metering device	The EEV precisely controls the flow of refrigerant by using programmed logic inside the PLC board. The PLC board monitors low side system pressure and temperature (superheat) to adjust the EEV to best position using over 480 control steps. Electronic Expansion Valves typically outperform standard expansion devices due to the programmable logic used to control refrigerant flow and maintain the designed superheat performance. The top electrical coil is removable and can be replaced without refrigerant removal. During refrigerant system maintenance, the EEV metering device can be opened or closed through the unit software or with an optional manual adjustment tool.
High Pressure Transducer (HPT)	Measure liquid line (high side) pressure	High side pressure is measured in the liquid line between the condenser and the evaporator coil. High side pressure is used by the PLC to monitor and control unit functionality including subcooling and condenser fan speed during elevated outdoor temperatures. By modulating the condenser fan speed based on high side system pressure, outdoor sound levels are reduced. High side system pressure and subcooling can be viewed through the unit or LC6000 software.
Low Pressure Transducer (LPT)	Measure suction line (low side) pressure	Low side pressure is measured in the suction line between the evaporator coil and compressor. Low side pressure is used by the PLC to monitor and control unit functionality including superheat and condenser fan speed during low outdoor temperatures. By modulating the condenser fan speed based on low side system pressure, compressor cooling can occur during low outdoor temperatures. Low side system pressure and superheat can be viewed through the unit or LC6000 software.
High Pressure Control Switch (HPC)	Refrigerant pressure safety device	The high pressure control provides a means of protecting each individual refrigeration circuit when extremely high system pressures occur. It is a auto-reset device that is connected to the Compressor Control Module.
Temperature Sensors	Function	Description
Discharge (Supply) Air Sensor (SAT)	Measure air temperature leaving unit	The discharge air sensor provides a temperature reading of the supply air leaving the unit. The sensor is a 10K OHM @ 77°F measuring device. It is installed in the return airstream after the evaporator coils.
Return Air Temperature Sensor (RAT)	Measuring air temperature entering unit	The return air sensor provides a temperature reading of the room air entering the unit. The sensor is a 10K OHM @ 77°F measuring device. It is installed in the return airstream behind the return grille.
Mixed Air Temperature Sensor (MAT)	Measure air temperature entering evaporator area	The mixed air sensor provides a temperature reading of the room air entering the unit after it is mixed with outdoor air entering the economizer. The sensor is a 10K OHM @ 77°F measuring device. It is installed in the Evaporator Fan area.
Freeze Sensor (FS)	Measure evaporator coil temperature	The 10K freeze sensor provides a way to monitor the evaporator coil temperatures, and help protect the system from a evaporator frost buildup/freeze event. Each evaporator coil has a sensor attached to the coldest location of the coil circuitry.
Outdoor Air Temp/Humidity Sensor (OAT) (OAH)	Measure outdoor temperature and humidity	The outdoor sensor measures outdoor temperature and humidity. This information is used for economizer and unit operation. It is located on the upper right side of the unit.
Air Pressure Sensors	Function	Description
Evaporator Fan Airflow Switch (AFS)	Verify indoor fan operation	The airflow switch measures the pressure differential between the Evaporator Fan inlet and outlet. A signal is sent to the PLC to indicate if the Evaporator Fan is not functioning.
Dirty Filter Switch Indicator (DFS)	Indicate indoor filter replacement needed	The switch is adjustable and measures pressure drop across the unit filter surface. When pressure drop is Higher than the switch setting a signal is sent to the PLC to indicate a filter change is necessary. A light is located on the exterior of the unit to indicate filters need to be replaced.



////// **Factory Supplied Unit Components List**

Electrical Components	Function	Description
Programmable Logic Board (PLC)	Control unit operation and communicate with main controlling device.	Each unit uses a programmable logic board located in the unit control panel to communicate with the LC6000 or other controlling device. By using a 2-wire connection, alarm functionality and unit operational commands are communicated. If communication is lost, the unit is able to provide cooling and heating by using the logic in the unit controller in orphan mode.
Compressor Control Module (CCM)	High system pressure and voltage brownout compressor protection	Each refrigerant circuit uses an individual compressor control module. The compressor control module locks out compressor operation to protect the refrigeration system based on signals from the High pressure switch. It provides diagnostics to indicate when a refrigerant pressure event occurs, and also sends a signal to the PLC. Low incoming voltage protection suspends compressor operation when incoming voltage is too low. Suspending compressor operation avoids reverse scroll operation. The voltage protection feature includes adjustable timing. An adjustable delay on break timer is provided. Delay on make is 2 mins. plus 10% of delay on break setting.
Phase Monitor (PM)	3 phase compressor phasing protection	Compressor protection device for 3 phase units. It monitors incoming power on a call for cooling and will not allow compressor operation if phasing is reversed, lost, or unbalanced. LED indicates phase monitor is on or registers fault code during a call for cooling from the unit PLC.
Compressor Contactor (CC)	Supplies power to compressor during a call for cooling.	The compressor contactor is energized during a call for cooling. When energized, it supplies power to components during the cooling cycle including the compressor. The compressor contactor is designed to carry the Amp load required for compressor operation. It is also rated for the many cycles needed to provide cooling to the conditioned area.
Circuit Breaker (CB)	Provides a means of disconnecting unit power and circuit protection for 200V to 240V units.	Circuit Breakers are provided for all units within a 200V to 240V incoming power range. Circuit Breakers are sized to meet the electrical requirements of the product including electric heater options, and provide a means to disconnect power at the unit. See Electrical Specifications Charts for electrical information. It is important to review and follow all electrical codes that apply to the application, and the electrical information provided in the specifications and installation instructions.
Toggle Disconnect (TD)	Provides a means of disconnecting unit power for 380V to 575V units.	Toggle disconnects are provided for all units within a 380V to 575V incoming power range. The toggle disconnect provides a means to disconnect power at the unit. See Electrical Specifications Charts for electrical information. It is important to review and follow all electrical codes that apply to the application, and the electrical information provided in the specifications and installation instructions.
Indoor and Outdoor Fans	Function	Description
Indoor Fan Assembly (IFM)	Provides indoor evaporator airflow	A backwards inclined industrial grade fan assembly is used to supply indoor airflow to the conditioned space. The fan is powered by a direct drive ECM fan motor that communicates with the PLC using Modbus.
Outdoor Fan Assembly (OFM)	Provides outdoor condenser airflow	An axial industrial grade fan assembly is used to supply outdoor airflow to the condenser coils. The fan is powered by a direct drive ECM fan motor that communicates with the PLC using Modbus.
Electric Heat Components	Function	Description
Heat Strip (HS)	Provides heat to area being conditioned	A rust resistant wire heating element that provides the listed BTUH amount in the Electric Heat Table. Electric heating elements are shipped with properly sized limit controls and breakers or disconnects. See Electrical Specifications Charts for electrical information.
Heat Contactor (HC)	Supplies power to heat strips during a call for heating.	The heat contactor is energized during a call for heating. When energized, it supplies power to components during the heating cycle including the heat strips. The heat contactor is designed to carry the Amp load required for heating operation. It is also rated for the many cycles needed to provide heating to the conditioned area.



## ////// Non-Ducted Supply and Return Grilles

Supply and return louver grilles are of a brushed aluminum or white finish. 2" flange versions are recommended for standard installations to allow grille attachment when large wall openings are present. Grilles are not supplied with the unit, and are ordered separately.

GRILLE NO.	UNITS USING GRILLE	DESCRIPTION OF LOUVER GRILLE	WEIGHT
SG-10W	W090A, W120A, W150A	16" x 43" with 2" Flange 4 way deflection supply grille. <b>Use for standard installations. Brushed Aluminum finish.</b>	6LBS (2.72KG)
RG-10W	W090A, W120A, W150A	22" x 43" with 2" Flange return grille with open egg-crate design. <b>Use for standard installations. Brushed Aluminum finish.</b>	12LBS (5.44KG)
SG-10W-W	W090A, W120A, W150A	16" x 43" with 2" Flange 4 way deflection supply grille. <b>Use for standard installations. White finish.</b>	6LBS (2.72KG)
RG-10W-W	W090A, W120A, W150A	22" x 43" with 2" Flange return grille with open egg-crate design. <b>Use for standard installations. White finish.</b>	12LBS (5.44KG)
SG-15W	W180B	16" x 55" with 2" Flange 4 way deflection supply grille. <b>Use for standard installations. Brushed Aluminum finish.</b>	9LBS (4.08KG)
RG-15W	W180B	22" x 55" with 2" Flange return with open egg-crate design. <b>Use for standard installations. Brushed Aluminum finish.</b>	18LBS (8.16KG)

## ////// Non-Ducted Supply Grille Throw Characteristics

SUPPLY GRILLE	AIRFLOW CFM	DEFLECTION	AK FACTOR	TOTAL PRESSURE	MAX. THROW
SG-10W	2682 CFM	0°	3.49	.044" WC	85 ft. (25.9m)
		22.5°	3.35	.049" WC	68 ft. (20.7m)
		45°	3.04	.074" WC	43 ft. (13.1m)
	3129 CFM	0°	3.49	.060" WC	91 ft. (27.7m)
		22.5°	3.35	.067" WC	73 ft. (22.3m)
		45°	3.04	.101" WC	46 ft. (14.0m)
	3576 CFM	0°	3.49	.078" WC	98 ft. (29.9m)
		22.5°	3.35	.087" WC	78 ft. (23.8m)
		45°	3.04	.132" WC	45 ft. (13.7m)
	4470 CFM	0°	3.49	.122" WC	109 ft. (33.2m)
		22.5°	3.35	.136" WC	87 ft. (26.5m)
		45°	3.04	.207" WC	55 ft. (16.76m)
5364 CFM	0°	3.49	.175" WC	120 ft. (36.6m)	
	22.5°	3.35	.196" WC	96 ft. (29.3m)	
	45°	3.04	.298" WC	60 ft. (18.3m)	

SUPPLY GRILLE	AIRFLOW CFM	DEFLECTION	AK FACTOR	TOTAL PRESSURE	MAX. THROW
SG-15W	5,740 CFM	0°	4.48	.122" WC	124 ft. (37.7m)
		22.5°	4.31	.136" WC	99 ft. (30.1m)
		45°	3.9	.207" WC	62 ft. (18.8m)
	6,888 CFM	0°	4.48	.175" WC	137 ft. (41.7m)
		22.5°	4.31	.196" WC	110 ft. (33.5m)
		45°	3.9	.298" WC	69 ft. (21.0m)
	8,036 CFM	0°	4.48	.238" WC	148 ft. (45.1m)
		22.5°	4.31	.267" WC	118 ft. (35.9m)
		45°	3.9	.406" WC	74 ft. (22.5m)
	9,184 CFM	0°	4.48	.288" WC	153 ft. (46.6m)
		22.5°	4.31	.337" WC	123 ft. (37.4m)
		45°	3.9	.474" WC	80 ft. (24.3m)
	10,332 CFM	0°	4.48	.366" WC	158 ft. (48.1m)
		22.5°	4.31	.454" WC	128 ft. (39.0m)
		45°	3.9	.542" WC	86 ft. (26.2m)



## Controller Overview

The MEGA-TEC® unit has many controls options to choose from. Selection of the right controls option will depend on how many units are being controlled, if remote communication via modbus or webpages is required, and how many alarms are needed to indicate building conditions or unit characteristics.

Here are a few typical MEGA-TEC controller setups:

- The **LC6000** is used to control 1 to 14 units in a building with 1 to 3 different climate zones. Both temperature and humidity are monitored. Each zone can monitor a temperature average using a wall or ceiling mounted sensors and unit return sensors. Multiple dry contact alarms are available from the LC6000 controller. Modbus and webpage remote access is available. Review wiring requirements in LC6000 specification sheet.

- The **PGDx** is used to control 1 unit in a building with 1 climate zone. Both temperature and humidity are monitored with sensors built into the PGDx. A single dry contact alarm is available from the MEGA-TEC to indicate a unit failure. Modbus and webpage remote access are not available. 18ga. to 22ga. connection wire is field supplied.

- The **PGD** is used to control 1 unit in a building with 1 climate zone. Temperature is monitored by the return air sensor in the unit (8620-306), or can use a remote temperature sensor (8620-307). A single dry contact alarm is available from the MEGA-TEC to indicate a unit failure. Modbus and webpage remote access are not available. An RJ11 cable is provided to connect the PGD to the MEGA-TEC and the PGD must be within 20ft. of the unit location.

CONTROLLER	FEATURES									
	# OF UNITS	# OF ZONES	ZONE MONITORING	HI SENSIBLE	BALANCED CLIMATE	ELECTRIC REHEAT	MODBUS	WEBPAGES	LOCAL ALARMS	WIRED ALARMS
<b>LC6000</b>	1 TO 14	1 TO 3	Temperature and Humidity	YES	YES	YES	YES	YES	YES	YES
<b>PGDx</b>	1	1	Temperature and Humidity	YES	YES	YES	NO	NO	YES	NO
<b>PGD</b>	1	1	Temperature Only	NO	NO	NO	NO	NO	YES	NO

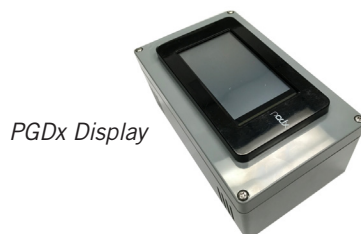

## LC6000 Multi-Unit Multi-Zone Temperature and Humidity Controller

The LC6000 controller allows for control of up to 14 units with 3 zones of operation. Special features including emergency vent, continuous ventilation, generator monitoring, and emergency off are standard features. Alarming, remote monitoring, and Modbus control give the technician piece of mind that units are operating efficiently and the air is conditioned inside the building.

Features of the LC6000:

- Temperature and humidity control of 1 to 3 zones.
- Controls 1 to 14 units.
- Webpages for remote system monitoring.
- Modbus remote alarming, monitoring, and control functionality.
- Wired alarming to a NOC or remote monitoring system.
- Comfort mode allows for temporary temperature settings while technicians are in the building.
- Emergency ventilation, emergency cooling, and emergency off features.

PART NUMBER	PART NAME	DESCRIPTION
<b>LC6000</b>	Multi-unit Controller	The LC6000 controller includes (2) EMI filters part #8301-055, (1) remote temperature and humidity sensor part #8403-079 with 35' of 18ga. 5-wire shielded cable with drain, and (1) TEC-EYE™ service tool with 5ft communication cable part #8301-059. Multiple zone operation will require purchase of a remote sensor for each zone that will be connected to the LC6000.



## LC6000 Controller Optional Accessories

PART NUMBER	PART NAME	DESCRIPTION
8403-079	Zone Temperature/Humidity Sensor	A temperature/humidity sensor is required for each zone of operation. (1) temperature/humidity sensor is included with the LC6000. The remote temperature/humidity sensor requires 18ga. 5-wire shielded cable with drain.
8301-058	Zone Temperature Sensor	An additional temperature sensor is optional for zone 1 temperature monitoring. Remote temperature sensors may be used in zones 2 and 3 instead of remote temperature/humidity sensors if humidity monitoring is not required in the zone. The remote temperature sensor is sold separately and requires 18ga. 2-wire shielded cable with drain.
8301-059	TEC-EYE™ Service Tool	The TEC-EYE™ service tool with 5 ft. communication cable is used to access software functions in the unit PLC board. The TEC-EYE™ is required for unit setup. (1) TEC-EYE™ service tool with 5 ft. communication cable is included with the LC6000 controller.
8301-053	Large Backlit Service Tool	The large backlit service tool is used to access software functions in the unit PLC board. Operation of the service tool is identical to the TEC-EYE™, but provides a large display area (2.8"x1.4") and mechanical entry keys. The large backlit service tool is sold separately.
8301-055	EMI Ferrite Filter	(1) EMI Ferrite filter is required on each end of the daisy chain connection between the units and the LC6000 controller. (2) EMI Ferrite filters are included with the LC6000 controller.
2151-021	EEV manual adjustment tool	The EEV manual adjustment tool allows for adjustment of the EEV (Electronic Expansion Valve) without the use of the unit logic board. The service technician can use this tool by removing the electronic head of the valve and attaching the adjustment tool. The tool houses magnets that interact with the valve to open or close the EEV for charging or evacuating the system without system power. The EEV manual adjustment tool is sold separately.

## LC6000 Daisy Chain Connection to Units

The MEGA-TEC® uses Modbus control to communicate between the logic board in the units and the logic board in the LC6000. Units and controller are connected using a shielded 2-wire daisy chain connection with a drain. Wires are polarity sensitive. The drain is connected to the LC6000 terminal block.

The LC6000 can be connected anywhere in the daisy chain. EMI line filters are used on the ends of the daisy chain. Only (2) EMI filters are required for the daisy chain, and are supplied with the LC6000 controller.

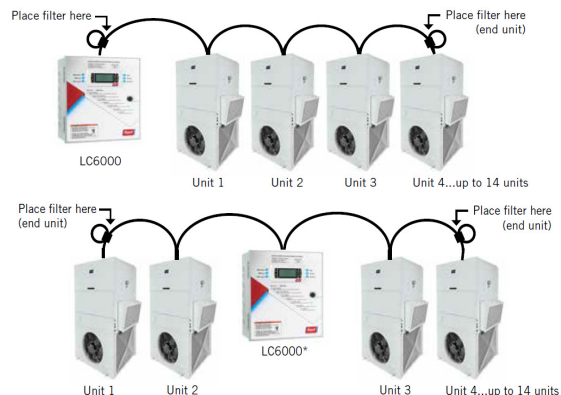

## LC6000 Wired Inputs for Site Equipment

FEATURE	DESCRIPTION
Emergency Off Input	Wired NO/NC* contact inputs are provided for connection to field supplied equipment. During an emergency off input event, a Modbus command to shut off unit operation is sent to units connected and communicating through the daisy chain. A emergency off event can be monitored remotely through a wired output and Ethernet connection. <b>It is important to follow all guidelines, codes, and requirements of smoke/fire suppression systems including the need to break power to the unit and close economizer dampers within a certain time period.</b> Additional relays, wiring, or field supplied accessories may need to be added to the units and equipment to achieve all requirements for the use of a smoke/fire suppression system.
Emergency Vent Input	Wired NO/NC* contact inputs are provided for connection to field supplied equipment. During an emergency vent input event, a Modbus command to open all unit economizer dampers is sent to units connected and communicating through the daisy chain. A emergency vent event can be monitored remotely through a wired output and Ethernet connection. <b>It is important to follow all guidelines, codes, and requirements of hydrogen monitoring systems including the use of a separate ventilation fan system when necessary.</b>
Generator Run Input	Wired NO/NC* contact inputs are provided for connection to a field supplied generator. During an generator input event, a Modbus command to limit the number of units that can be operated is sent to units connected and communicating through the daisy chain. A generator event can be monitored remotely through a wired output and Ethernet connection. <b>It is important to set the limitation of how many units can run during a generator event when using the generator run input (defaults to 0 units).</b> Individual unit operation is selectable for a generator event.

## //////// LC6000 Wired Alarm Outputs

FEATURE	DESCRIPTION
Emergency Off Alarm	Wired NO*/NC contact outputs are provided. During an emergency off input event, an alarm is sent to the contact output.
Emergency Vent Alarm	Wired NO*/NC contact outputs are provided. During an emergency vent input event, an alarm is sent to the contact output.
Generator Run Alarm	Wired NO*/NC contact outputs are provided. During a generator run input event, an alarm is sent to the contact output.
Bard Guard Alarm	Wired NO*/NC contact outputs are provided. During an Bard Guard input event, an alarm is sent to the contact output.
Indoor Humidity Alarm	Wired NO*/NC contact outputs are provided. During a high humidity event where humidity levels have exceeded the maximum humidity alarm setting in any zone of operation, an alarm is sent to the contact output. The default low humidity alarm setting is 20%. The default High humidity alarm setting is 85%.
High Indoor Temperature Alarm	Wired NO*/NC contact outputs are provided. During a high temperature event where indoor temperature has exceeded the High temperature alarm setting in any zone of operation, an alarm is sent to the contact output. The high temperature 2 alarm is set to 90°F by default.
Low Indoor Temperature Alarm	Wired NO*/NC contact outputs are provided. During a low temperature event where indoor temperature is below the low temperature alarm setting in any zone of operation, an alarm is sent to the contact output. The low temperature alarm is set to 45°F by default.
Zone 1 Unit Alarm	Wired NO*/NC contact outputs are provided. This feature allows the user to configure what unit alarm conditions are going to be sent to the alarm contacts for Zone 1. A zone unit alarm can contain any of the following unit alarms: Blower Failure, Dirty Condenser Coil, Economizer Dust Alarm, Economizer Fail, EEV Failure, Dirty Filter Alarm, Freezestat Active, High Refrigerant Pressure, Low Refrigerant Pressure, Return Air High/Low Alarm, Sensor Fail Alarm, Supply Air High/Low Alarm, and Unit Power Loss Alarm. The default configuration is to alarm on a unit high or low pressure event.
Zone 2 Unit Alarm	Wired NO*/NC contact outputs are provided. This feature allows the user to configure what unit alarm conditions are going to be sent to the alarm contacts for Zone 2. A zone unit alarm can contain any of the following unit alarms: Blower Failure, Dirty Condenser Coil, Economizer Dust Alarm, Economizer Fail, EEV Failure, Dirty Filter Alarm, Freezestat Active, High Refrigerant Pressure, Low Refrigerant Pressure, Return Air High/Low Alarm, Sensor Fail Alarm, Supply Air High/Low Alarm, and Unit Power Loss Alarm. The default configuration is to alarm on a unit high or low pressure event.
Zone 3 Unit Alarm	Wired NO*/NC contact outputs are provided. This feature allows the user to configure what unit alarm conditions are going to be sent to the alarm contacts for Zone 3. A zone unit alarm can contain any of the following unit alarms: Blower Failure, Dirty Condenser Coil, Economizer Dust Alarm, Economizer Fail, EEV Failure, Dirty Filter Alarm, Freezestat Active, High Refrigerant Pressure, Low Refrigerant Pressure, Return Air High/Low Alarm, Sensor Fail Alarm, Supply Air High/Low Alarm, and Unit Power Loss Alarm. The default configuration is to alarm on a unit high or low pressure event.

## //////// LC6000 Remote Connectivity Options

FEATURE	DESCRIPTION
Ethernet Connection	Ethernet access to all connected equipment is available through the LC6000 controller. A integrated Ethernet port is located on the programmable logic board located inside the LC6000. When connected to a network, the connection allows for remote monitoring using software from a remote location. The Ethernet connection uses Internet Protocol Version 4 (IPV4). When using the Ethernet connection, it is important for the user to provide appropriate Ethernet network security measures.
Modbus Remote Access	By using the ethernet connection, the controller will respond to Modbus commands allowing access to set points, alarms, temperature measurements and humidity measurements for each zone. The measurement units (English/Metric) retrieved during communication are determined by the controller unit of measure setting. This is configured on-site and cannot be changed remotely. For more information about setting measurement units, please refer to the latest version of the 2100-669 LC6000 Service Instructions manual. Modbus addressing instructions and register points are available in the latest version of the Modbus Supplemental Manual 7960-791.
Webpage Remote Access	Webpages allow controller access with a computer using a standard web browser. The web browser graphical interface provides a visual look at unit operation, viewing and adjustment of zone indoor conditions, alarm events, data trending, and a virtual interface of the display/buttons used on the LC6000 controller. By using the Ethernet connection, the controller can be accessed through webpages.
Optional BACnet and SNMP Gateway Kit Bard part #8620-350	The Optional BACnet/SNMP gateway kit contains the DIN rail mounted gateway with both RS485 connections and an ethernet port along with a wire harness to connect power from the LC6000 to the gateway. Once installed, the gateway is inside the LC6000 enclosure. See installation instructions 7960-791 for features and installation procedures.



# MEGA-TEC Unit with TEC-EYE Interface

## Main TEC-EYE Interface and Display When Connected to Unit

The TEC-EYE service tool is used to interface with the unit PLC board. When connected, it provides unit information along with a way to set the unit up for operation with the LC6000, PGDx, or PGD unit controller.

One TEC-EYE tool is supplied with both the LC6000 and the PGDx controller. The PGD controller displays the same information as the TEC-EYE and uses the RJ11 connection. The optional large display service tool Bard part #8301-059 provides a larger display and larger non-membrane keypad buttons for easier data entry and is recommended for setting up larger quantities of units.

Unit Control Panel

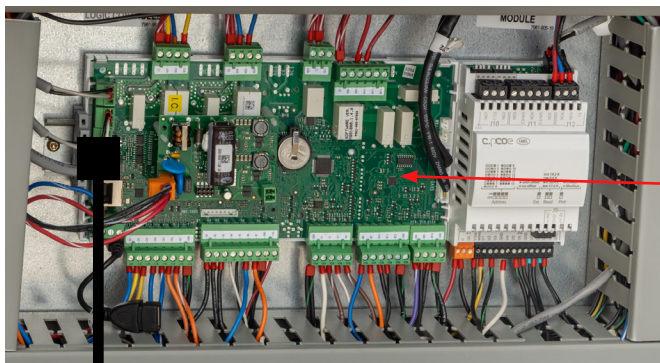

MEGA-TEC Unit PLC Board

The unit PLC board is located inside the unit control panel area.

Connection Cable

Cable with RJ11 connectors on each end that plugs into the port located on the PLC board and into the back of the TEC-EYE tool.

TEC-EYE Service and Setup Tool

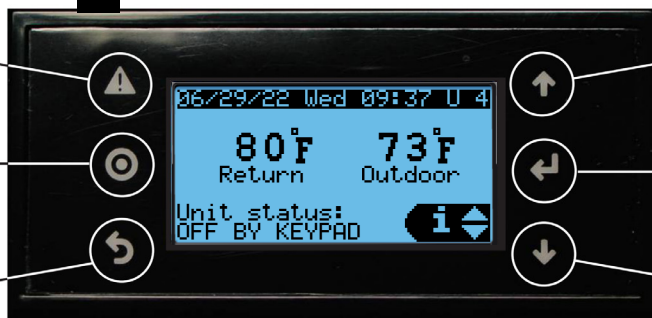

Alarms Key

Push button to view any alarms currently stored in the unit software.

Configuration Menu Key

Push button to enter configuration and setup menus.

Back/Escape Key

Push button to backup in menu or escape to main display screen.

Up Key

Push button to move up in the menu structure.

Enter Key

Push button to select or confirm choices in the menu structure.

Down Key

Push button to move down in the menu structure.

Date and Time

Displays the date and time that is set up by the user in the settings configuration menu or provided by the LC6000.

Return Air Temperature

Displays the temperature of the return airstream entering the unit.

Unit Status

Displays the unit mode of operation occurring currently.

Unit Address

Shows the unit address of the unit. With multiple units, each one is given a number (address) that will be referenced by the LC6000 lead/lag controller.

Outdoor Temperature

Displays the unit outdoor temperature sensor reading.

Main Screen Display Options

Used to review unit operation and stand alone temperature settings.

TEC-EYE Main Display Screen

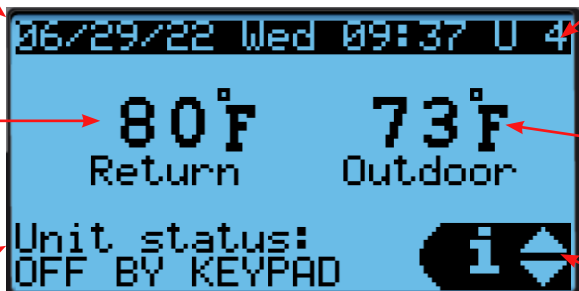



**TEC-EYE Main Screen Informational Menu**

The information screen provides various information regarding unit operation for the unit. To access the information screen, the technician will press the up/down arrows on the main screen, then Enter at the "i" displayed in the lower right corner.

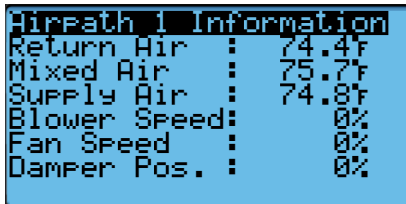

**Airpath 1**

This screen provides data on the left side unit airpath including air temperatures, indoor fan speed, outdoor fan speed and economizer damper position.

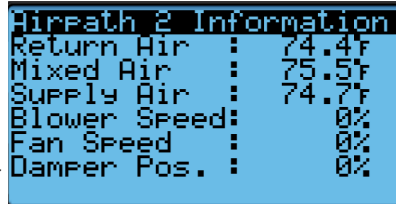

**Airpath 2**

This screen provides data on the right side unit airpath including air temperatures, indoor fan speed, outdoor fan speed and economizer damper position.

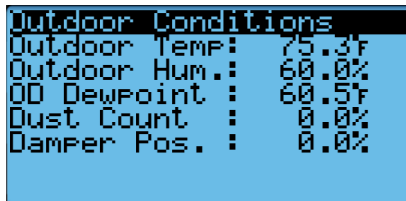

**Outdoor Conditions**

This screen provides information on outdoor conditions based on readings from the outdoor sensor mounter to the right side of the unit.

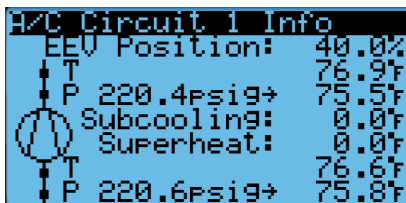

**A/C Circuit 1 Info**

This screen provides information on the left side unit refrigeration system including superheat, subcooling, and system pressures.

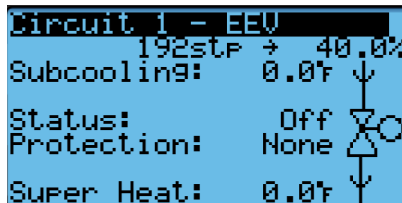

**Circuit 1 EEV**

This screen provides information on the left side EEV including step position.

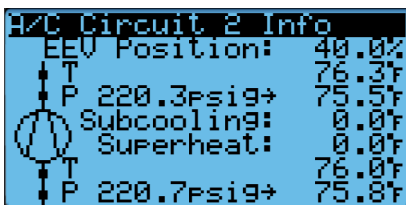

**A/C Circuit 2 Info**

This screen provides information on the right side unit refrigeration system including superheat, subcooling, and system pressures.

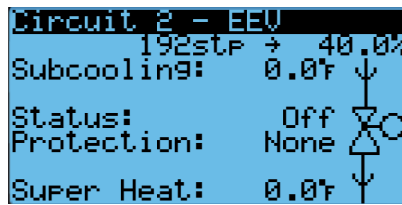

**Circuit 2 EEV**

This screen provides information on the right side EEV including step position.

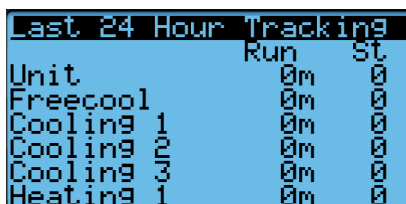

**Last 24 Hour Tracking**

This screen provides unit run information for the past 24 hours. Information includes runtime for heating and cooling stages along with economizer free cooling.

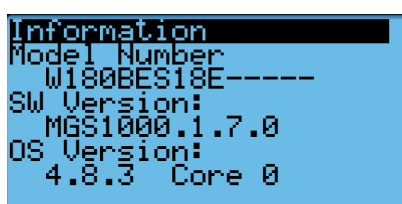

**Information**

This screen reflects the unit model number, software version, and operating system version being used.



**TEC-EYE Main Setpoint Menu**

The setpoint screen allows for a temperature setpoint to be adjusted and used without using the LC6000 or PGDx controller. When the MEGA-TEC unit is connected to the LC6000 or PGDx, the temperature setpoints in the controller will override the setpoints in the unit setpoint menu. If the PGD is used, these will be the setpoints for unit operation.

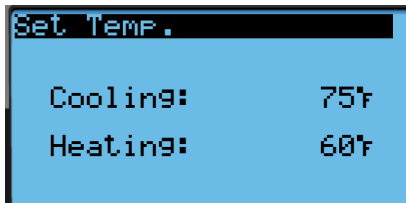

**Set Temp.**

A cooling and heating setpoint can be entered in this menu. Once entered, the unit will operate using the setpoints based on the return air temperature sensor. When a LC6000 or PGDx is connected to the MEGA-TEC unit, these settings will no longer apply. If the MEGA-TEC loses communication with the LC6000 or PGDx, the last setpoints recieved from the controller will be used when running in orphan mode until communication with the controller is restored.



**Data Log Menu**

The data event log screen records and displays any active or recorded alarms or events that have occurred since the alarms were cleared.

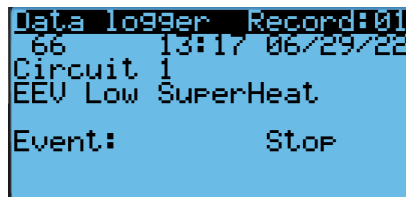

**Data Logger**

Data logger events are displayed including a date and time stamp. A brief description describes the event. Start indicates when the event started, and an indicator also will show when the event stopped. To clear events, go into the alarm log screen by pressing the triangle with exclamation mark symbol in the upper left corner of the TEC-EYE and follow the directions provided on the screen.



# TEC-EYE Configuration Menu Features

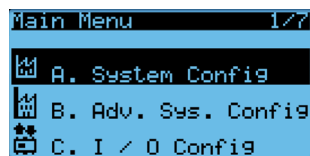

## TEC-EYE Configuration Menu

The configuration menu is where certain functions and features of the MEGA-TEC can be accessed and set up for use. Accessing these features requires a password, and the menu structure consists of the following:

- *System Configuration:* This menu provides the standard setup features of the unit, and must be reviewed during unit installation. See below for full list of options.
- *Advanced System Configuration:* This menu provides advanced settings that are not normally required for standard unit operation. See below for full list of options.
- *I/O Configuration:* I/O configuration is not normally required for standard unit setup.
- *ON/OFF:* Allows the unit operation to be disabled using the TEC-EYE.
- *Alarm Logs:* Shows a full list of alarms logged. Clearing the alarm logs will remove the alarms that are not currently active.
- *Settings:* Date/Time, Passwords, and initialization (factory reset) are all commands available from the settings menu. Daylight savings time zone configuration, passwords for USER, SERVICE, and MANUFACTURER can all be setup from the settings menu.
- *Log Out:* Logs out the current user and requires password for entry into the configuration menu.

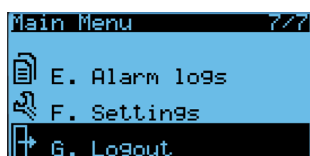
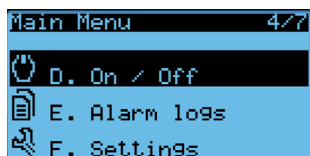

## System Configuration Menu



### Unit Setup

Each unit when used with the LC6000 is assigned a different address (1-14) and a zone (1-3). Units of measure can be selected (USA, SI, Lon, CAN, UK).

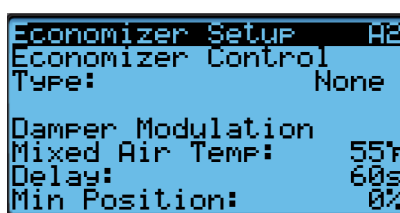

### Economizer Setup

Allows setup of economizer features (none, temp/hum, enthalpy, dry bulb) and setpoints. **Economizer settings in the LC6000 will override these settings when connected.**

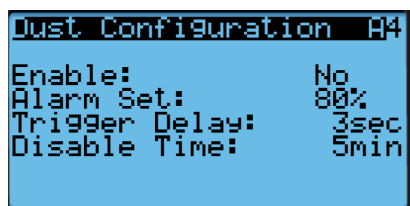

### Dust Configuration

Used to enable/disable dust alarm, adjust when the alarm will disable the economizer and for how long it will be disabled.

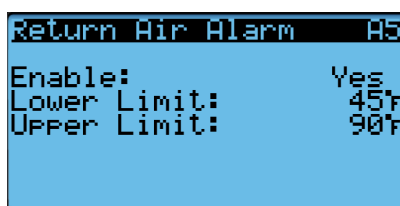

### Return Air Alarm

This feature will allow the software to send an alarm when the return air temperature is outside the upper and lower limit.

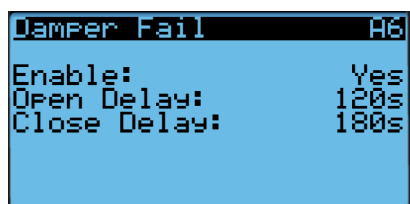

### Damper Fail

This feature will allow the software to send an alarm when one of the economizer damper switches indicates the dampers have failed to closed.

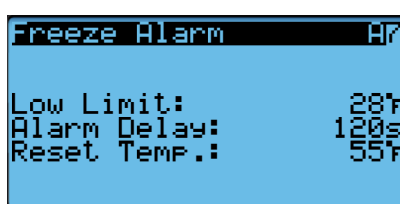

### Freeze Alarm

This feature will allow the software to send an alarm when the supply air temperature is below the lower limit.

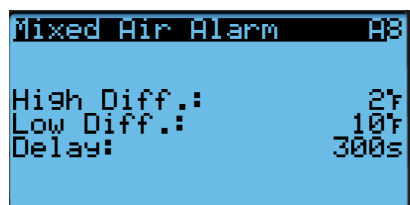

### Mixed Air Alarm

This feature will allow the software to send an alarm when the return air temperature is outside the upper and lower differential when using the economizer.

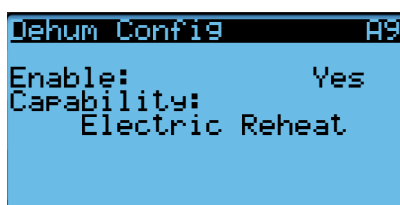

### Dehum Config

This feature will allow the user to enable or disable electric reheat if the unit is equipped (capability) with the optional feature.

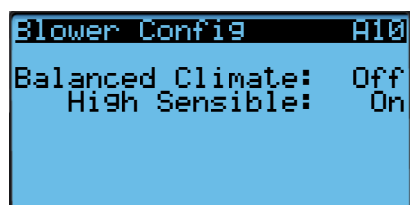

### Blower Config

This menu allows the user to enable Balanced Climate mode (enhanced moisture removal) and High Sensible (increased sensible cooling capacity). **Balanced Climate is off by default.**

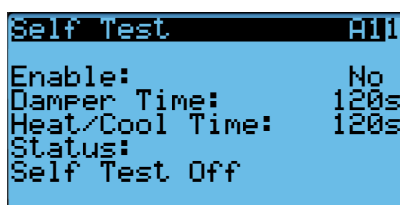

### Self Test

This feature will allow the user to verify indoor/outdoor fan, compressor, ventilation, and electric heat operation.



## //////// Advanced System Configuration Menu

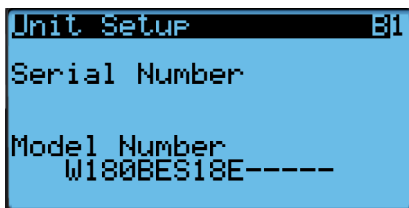

**Unit Setup**  
Provides the model and serial number of the unit. This will be pre-set from the factory to match the unit.

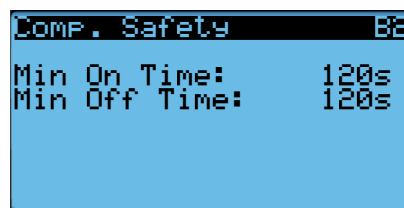

**Compressor Safety Settings**  
Adjusts minimum run time and off time between cooling cycles. This command is used to avoid compressor short cycling, and for standard operation no adjustment is required.

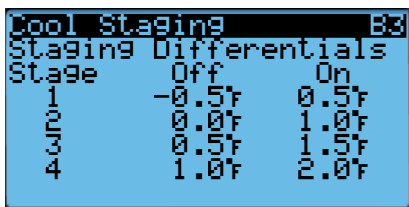

**Cooling Staging**  
Adjusts cooling staging temperature differentials for single unit operation. If unit is connected to the LC6000, these settings will not be used.

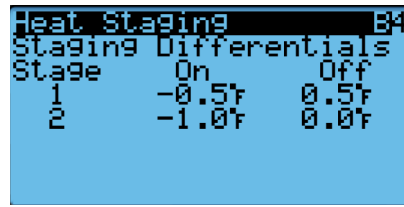

**Heating Staging**  
Adjusts heating staging temperature differentials for single unit operation. If unit is connected to the LC6000, these settings will not be used.

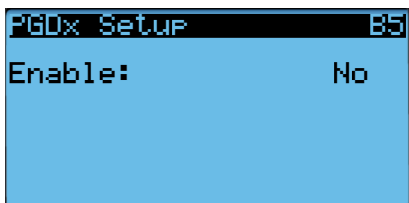

**PGDx Setup**  
This command must be enabled if the PGDx single unit controller is used.

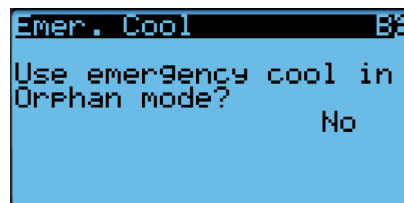

**Emergency Cool**  
Allows emergency cooling (open ventilation to 100%) to operate if a return air alarm is active and the unit is disconnected from the LC6000.

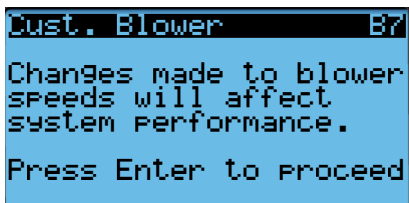

**Custom Blower Speeds**  
This feature will allow manual adjustment of the unit indoor airflow for cooling and economizer operation. See unit manual for additional details.

## //////// I/O Configuration Menu

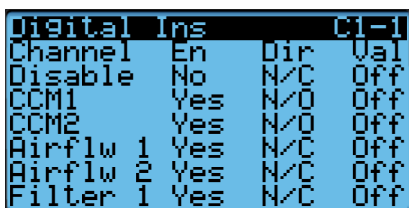

**Digital Inputs**  
Unit disable can be enabled through the I/O input menu and contacts can be either normally open (NO) or normally closed (NC).

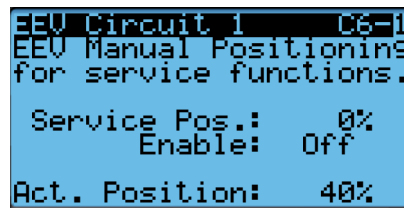

**Manual EEV Adjustment**  
Both Electronic Expansion Valves can be opened manually in case service work on the refrigeration circuit is necessary.

## //////// Unit Field Communication Connections in MEGA-TEC Control Panel

The MEGA-TEC unit control panel provides field connections for communication between units and the LC6000 controller using Modbus. There are also Connections for the PGDx single unit controller and unit fail alarm contacts for wired alarming in case of a refrigeration event disabling unit operation.

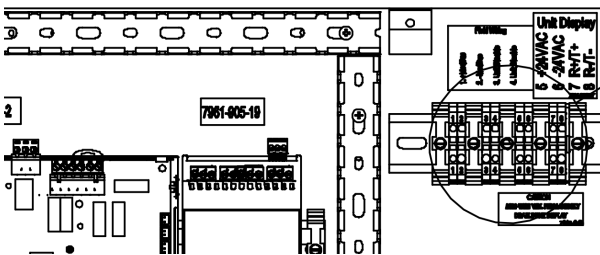

Terminal	Description
1	+ Connection for Unit Daisy Chain Modbus
2	- Connection for Unit Daisy Chain Modbus
3	Unit Disable Dry Contacts (enabled in I/O Config)
4	Unit Disable Dry Contacts (enabled in I/O Config)
5	PGDx Unit Display Power Connection +24VAC
6	PGDx Unit Display Power Connection -24VAC
7	PGDx R+/T+ Communication Wire
8	PGDx R-/T- Communication Wire
9	Unit Fail Alarm Contacts, Normally Open (NO)
10	Unit Fail Alarm Contacts, Common (COM)
11	Unit Fail Alarm Contacts, Normally Closed (NC)



Bard Manufacturing Company, Inc.  
1914 Randolph Dr., Bryan, OH 43506  
419-636-1194

[www.bardhvac.com](http://www.bardhvac.com)

Due to our continuous product improvement policy, all specifications subject to change without notice.

